

1.0 Introduction	4	5.0 Good Practice Examples	17	6.0 Appendices	36
1.1 Local Authorities	5	5.0 Design Suggestions	19	6.1 Understanding Light	37
1.2 Primary Lighting Principles	6	5.0 Precedents	20	6.2 Relevant Standards & Professional Guidance Documents	38
2.0 Context	7	5.1 Bad Residential Lighting	21	6.3 Relevant Research on Light Pollution Impacts	39
2.1 Value of Dark Skies	8	5.2 Good Residential Lighting	22	6.4 Example Conditions	40
2.2 Good Lighting Outcomes	9	5.3 Bad Commercial & Residential Lighting	23	6.5 Local Plan Policies	42
3.0 Light Pollution & Obtrusive Lighting	10	5.4 Good Commercial & Residential Lighting	24	6.6 SQM Readings	43
3.1 Types	11	5.4 Bad Industrial Lighting	25	6.7 LUX Readings	44
4.0 Planning Process and Lighting Assessment & Design	12	5.5 Good Industrial Lighting	26	6.8 Visual Information	45
4.1 Lighting Assessment & Design	13	5.6 Bad Farm Lighting	27	6.9 Plan Drawings	46
4.2 Understanding the Baseline	14	5.7 Good Farm Lighting	28	6.10 Lighting Specification	47
4.3 Planning Process, Lighting Assessment & Design	15	5.8 Bad Sports Lighting	29	6.11 Lighting Details	48
		5.9 Good Sports Lighting	30	6.12 Lighting Calculations	49
		5.10 Bad Heritage & Architectural Lighting	31	6.13 Improving Existing Lighting	51
		5.11 Good Heritage & Architectural Lighting	32	6.14 Luminaire & Source Selection	52
		5.12 Bad Campsite Lighting	33	6.15 Energy	53
		5.13 Good Campsite Lighting	34	6.16 Checklist	54
		5.14 Ad Displays, Event Lighting, Innovative Tech & CCTV	35		

“For millennia, on every clear night, humans have wondered at the awe-inspiring spectacle of the starry heavens...The light from distant stars and galaxies takes hundreds, thousands, even millions of years to reach us – what a tragedy to lose it in the last millisecond of its journey.”

*Bob Mizon, Commission for Dark Skies,
Disappearing Stars*



**British
Astronomical
Association**



**Royal
Astronomical
Society**



Commission for Dark Skies



buglife



**NATURAL
ENGLAND**



**Cumbria
Wildlife Trust**



**DarkSky
INTERNATIONAL**



**Solway
Coast**

Area of Outstanding
Natural Beauty



**Arnside &
Silverdale**

Area of Outstanding Natural Beauty



NORTH PENNINES

Area of Outstanding Natural Beauty



United Nations
Educational, Scientific and
Cultural Organization

North Pennines
UNESCO
Global Geopark



The
countryside
charity



**CAMPAIGN for
NATIONAL PARKS**



**UK DARK SKIES
PARTNERSHIP**



dark source

This Technical Advice Note (TAN) has been developed by **Dark Source** Lighting Design Studio and **Friends of the Lake District** (CPRE - The Countryside Charity, Cumbria branch) in collaboration with the local planning authorities to provide technical lighting guidance to planners, applicants, architects, developers, electricians, property owners, communities and lighting professionals.

The TAN gives guidance on the necessary information to submit with planning applications, other consents (such as Notifications of Intent and Listed Building) and to inform the lighting design process, in order to conserve and enhance the Dark Skies across Cumbria & YDNP.

Even where planning consent is not required, those seeking to install new lighting or replace existing lighting can play their part by following the Good Lighting Principles.

The guidance covers

- The importance of Dark Skies to Cumbria;
- Good lighting principles;
- Positive lighting outcomes delivered through getting lighting right;
- Different forms of light pollution and their impacts;
- The role of the TAN in the planning process;
- The planning and lighting Design process;
- What good practice looks like through visuals and examples;
- Relevant background information in technical appendices, including a Glossary, 'Understanding Light' and reference/further reading list.

TAN Production Process:

Following a Tender process, Dark Source lighting consultancy was engaged by Friends of the Lake District (representing CPRE - The Countryside Charity in Cumbria) on behalf of all nine local planning authorities (LPAs) covering Cumbria at the time to produce this Good Lighting Technical Advice Note (TAN). A Project Steering Group included Officers from three LPAs, along with FLD's Planning Officer and Dark Skies Officer. Similar planning guidance documents are operating in other areas across the UK, reflecting the growing concerns over the impacts of light pollution on people and the environment.

Production of the initial draft (Sept-Dec 2022) was discussed at a Cumbria Planning Training Scheme event in December 2022. Amendments were made to the Draft TAN, which was published in January 2023 and circulated to diverse stakeholders for wider consultation and feedback. During Jan-March 2023 we received over 200 comments and recommended changes to the TAN from Architects, Crime Prevention Officers, Planning Officers, Lighting Designers and Engineers, Professional Lighting Consultants and Academics and manufacturers and other relevant bodies, such as the Campaign for National Parks and the Royal Astronomy Society. Following this the TAN was amended and approved by the Steering Group in July 2023, and the final TAN was then approved for use by the relevant LPAs to cover Cumbria, the whole of the Yorkshire Dales National Park, and also the Lancashire part of the Arnsdale and Silverdale National Landscape.

You can view the summary TAN document [here](#).

The application of this TAN will:

- a) Assist local planning authorities to implement their Local Plan policies on light pollution and achieve other relevant policy objectives (eg. climate, biodiversity, landscape character and well-being);
- b) Inform the development of new policies to strengthen good lighting principles, including Neighbourhood Plans and Design Codes; and
- c) Provide clear information on lighting to support development management, compliance and other public relevant services (eg. crime prevention/safer streets, environmental protection) decisions;
- d) Raise awareness and empower all to make good lighting choices and ensure lighting best practice;
- e) Achieve a net reduction in light pollution.

Information on the relevant local plan policies are shown in **Appendix 6.5 "Overview of Local Plan Relevant Policies."** These will be continuously updated as new policies get developed. Retained policies under the two new Unitary Authorities - Cumberland and Westmorland & Furness – are listed under the previous Borough, City and District areas to show where they apply.

This TAN is approved and applies in the following planning authority areas:

Cumberland, Westmorland & Furness, the Lake District National Park, the Arnside & Silverdale National Landscape within the Lancaster District, and the Yorkshire Dales National Park ('the TAN area') (see map across, and on **page 12**).



Before April 1st 2023



After April 1st 2023

The Yorkshire Dales National Park became an International Dark Sky Reserve in December 2020 (See map).

The National Park Authority will apply the Good Lighting TAN across the whole of the National Park area alongside their existing lighting tips and guidance: **Good lighting advice - Yorkshire Dales National Park : Yorkshire Dales National Park**



1. Don't light unless it's necessary.
Is the light really needed to fulfil a clear task or function?



2. Light only what needs to be lit.
Avoid over lighting and clutter, direct light downwards and use the correct beam distribution.



3. Light should be no brighter than necessary.
Our vision is harmed when intense light glares. Use lighting sensitively, and ensure it's comfortable on the eye.



4. Use warm colour temperatures.
2,700 Kelvins or lower utilised throughout.



5. Use switch off, dimming or PIR sensors.
Only have lights on when needed, and help reduce carbon emissions and save on your electricity bills.



6. Use lower mounting height where possible.
Lower mounting height contains light more effectively.



7. Limit internal lighting spilling outside
Avoid extensive glazing, fit blinds, external shutters and/or use tinted or electrochromic glass.



8. Keep light away from wildlife.
Nature needs darkness to function and be healthy.

Lighting Professionals have adopted the Responsible Outdoor, Lighting At Night (ROLAN) Manifesto core principles which reflects the advice contained in this Good Lighting TAN, see: [Responsible Outdoor Lighting at Night \(ROLAN\) Manifesto for Lighting Professionals \(cibse.org\)](#)

Lighting Urban Community International (LUCI) Association declared their sustainability goals which are aligned with the principles outlined in this document, see: [Declaration for the Future of Urban Lighting](#)



A SPECIAL PLACE TO CONSERVE & ENHANCE.

Cumbria is a large, diverse County, with a rich cultural and natural environment, with stunning landscapes, historic towns and cities, an extensive coastline, major river catchments, glaciated valleys, dales, high fells and mountain summits. There are extensive areas with limited development, characterised by landscape tranquillity, hence 62% of the County's night skies are in the darkest category ([See UK's Light Pollution and Dark Skies - cpre.org.uk](#)).

- The beauty of Cumbria, including at night, is reflected in the County's £2.9 billion+ tourism sector, and major opportunities to grow the environmental economy to underpin overall environmental health and climate resilience.
- 56% of Cumbria's landscapes are designated, including two National Parks, three Areas of Outstanding Natural Beauty and a Heritage Coast. The Yorkshire Dales National Park is an International Dark Sky Reserve. [Link](#).
- 36% of Cumbria is covered by one of two World Heritage Site designations - the English Lake District and Hadrian's Wall, North Pennines National Landscape & UNESCO Global Geopark, along with Scheduled Monuments, Conservation Areas, listed buildings and locally important heritage assets.
- 25-30% of Cumbria are significant biodiversity habitats: National Nature Reserves, Sites of Special Scientific Interest, Special Protection Areas, Special Areas of Conservation and Ramsar sites, with a further 40 Local Nature Reserves, over 1600 County Wildlife Sites and significant areas of priority habitat.
- 31% of England's Common Land is within Cumbria, the highest proportion in any county in the Country, which by virtue of its rural un-developed nature, provides fantastic accessible spaces to experience the darkest skies.
- Cumbria's rivers, major estuaries, iconic Lake District lakes, tarns and water bodies are central to sustaining the natural environment, wildlife and people.

The planning system plays a vital role in conserving and enhancing these assets and the TAN will help reverse the piecemeal erosion of our dark skies. Getting lighting right achieves multiple wider benefits, including efforts to mitigate climate change, protect biodiversity and improve our health and well-being. It also helps to diversify the economy, by helping to protect the tranquillity that people come here to experience and by creating

Cumbria has some of the UK's darkest skies; areas that according to The Dark Sky International "are naturally dark at night and free of light pollution", and, therefore, some of the best places in the world to view the beauty of the night sky, protect natural ecosystems and prevent the wasteful use of energy.

'Dark Skies' is an over-arching term used in this TAN to convey several facets of light pollution. It does not only apply to keeping the sky dark, but it applies all to all urban and rural landscapes below. Dark Skies are a crucial resource and infrastructure upon which Cumbria's natural environment, biodiversity, well-being and economy heavily relies. They encourage tourism, boost biodiversity, create a pleasant living environment, reduce energy usage and save money.

Areas that are already dark should be protected to remain dark, whilst areas that contain high levels of illumination should strive to reduce their lighting footprint. This does not mean that towns and built-up areas are asked to become pitched in darkness! The guidance within this TAN fully embraces a duty of care to provide lighting to satisfy amenity, legibility, wayfinding and health & safety expectations, and does not seek to eliminate or ban lighting.

In Cumbria we are a pioneer in seeking a net reduction of light pollution. This represents an opportunity to embed lighting into a broader planning policy context, ensuring that new or replacement lighting does not add to, and where possible reduces, light pollution levels. This includes taking measures to reduce and limit new light pollution even in areas where there is already significant artificial light.

We can achieve this with the help of this TAN, the highway lighting design specification and wider pro-active initiatives.



1) Energy and Carbon Savings - Artificial lighting is a precious resource not to be wasted. Lighting can account up to nearly 6% of the global CO2 emissions and 20% of the electricity used worldwide. Wasteful poor lighting undermines the Zero Carbon Cumbria's net zero target by 2037. Install the minimum number of lights to fulfil the task. Choose lights with the lowest embodied energy. Achieve maximum efficiency of Lumen output per Watt. Lights to be on only when required. (See page 53)



Plas Y Brenin National Outdoor Centre (Snowdonia Nation Park) lighting design project eliminated the light pollution whilst reducing the annual energy waste by 2 tonnes of CO2 (80%).

2) Attractive and Safe Spaces - Sensitive lighting contributes to place-making, inclusive spaces, public realm character and ambience. Uniformity and legible visibility is lost through harsh lighting glare and cluttered/disorienting light sources. Retain natural darkness in green spaces wherever possible.

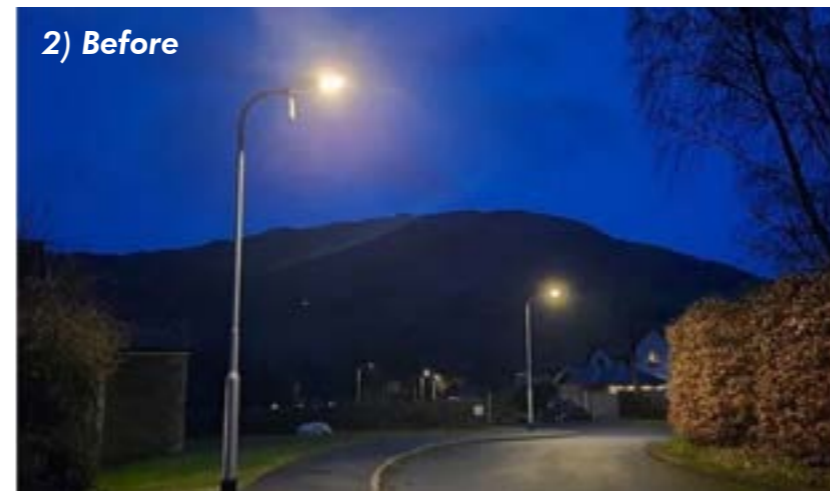

Glenridding lighting project used Night-Tune luminaires specially developed to utilise adaptable warm colour temperature at lower mounting height whilst allowing safe access & legibility throughout the site.

3) Residential Amenity & Well-Being - Protecting residential amenity is an established planning consideration, and common law 'quiet enjoyment' of your property. Good lighting minimises disruption to people's sleep and prevents light spill causing nuisance. During the hours of darkness humans produce the hormone Melatonin, which is an antioxidant, anti-inflammatory, and reduces blood vessel permeability, anxiety and stress. Seeing the stars connects people to nature improving mental and physical well-being.



Cliff Terrace, Kendal lighting project illustrates how day & night-time character of a street can be improved through using heritage lanterns with warm colour temperature which match the fabric of the residential context whilst eliminating the light spill on the facades.

4) Enjoying Dark Skies Heritage - Astro-tourism and Astro-photography are growing in popularity, particularly valuable for increasing staying visitors over the winter months and providing much needed income to different parts of Cumbria. Reversing sky glow from preventing lighting shining above the horizontal plane is vital.



Castlerigg (left) with the light pollution coming from Keswick in the background.

Insects (right) are fatally attracted to a street light at night.

5) Protecting Biodiversity - The day and night (light and dark) cycle is encoded in the DNA of all living creatures, and darkness is essential for nature to flourish. Planning decisions consider biodiversity net gain and Cumbria is a leading area for nature recovery. All lighting must be sensitive to the habitats and species directly or potentially affected.

WHAT IS LIGHT POLLUTION?

- Light pollution is the sum total of all the adverse effects of artificial (anthropogenic) light, including on ecosystems, dark skies, landscapes or other areas, and on people.
- Artificial light that goes where it's not supposed to go – a neighbour's window or up into the night sky.
- Artificial light that's excessive, obtrusive, harmful and ultimately wasteful in electricity.



Sky glow is the brightening of the night sky seen across the horizon – ‘halo-effect’ - as a result of badly directed upward and horizontal beams of light illuminating aerosols, water molecules and atmospheric particles. This scattering of light creates the sky glow, blocking our ability to observe the night sky and see the stars. Cumbria’s western coastal location, high rainfall and moist atmosphere increases the effects of skyglow.

The satellite map ([on page 14](#)) shows the significant light pollution sources across Cumbria, and how this spreads well beyond the location of the light sources. Ground-truthing measurements using Sky Quality Meters across the County show how sky glow can affect the night sky up to 10-15 miles distance away, for example, Penrith affecting the north-east Lake District and Sellafield affecting the iconic western valleys.



Glare is excessive levels of illuminance causing visual discomfort and nuisance. Light should be directed to where it is needed, with little of the source visible from surrounding areas. Easily fitted, low cost off-the-shelf ‘security’ floodlights are commonly being installed on commercial and domestic properties. Often without consideration of the glare they create and some types higher illuminance than nearby street lighting.

Glare may result directly from lighting or indirectly off surfaces by reflecting light. Highly reflective surfaces are an important factor to consider in Cumbria, with high rainfall/wetter surfaces, significant water bodies and limestone areas, for example. Individual or multiple luminaires (light cluttering) can cause harmful glaring.

The four main forms of Glare are:

Distraction glare represents an annoyance or distraction to the viewer and can lead to eye fatigue.

Discomforting glare occurs in varying degrees of intensity results in visual discomfort, often shown by symptoms of eyestrain or fatigue. The response is people squinting, shielding their eyes or turning another direction as their eye pupil constricts.

Disabling glare is more intense than discomforting glare and the high level of light produces a glare that can actually interfere with or block vision, reducing the sharpness of vision.

Blinding glare results from light reflecting off smooth, shiny surfaces such as metal, water or snow. It can be strong enough to block vision to the extent that the viewer becomes visually compromised.

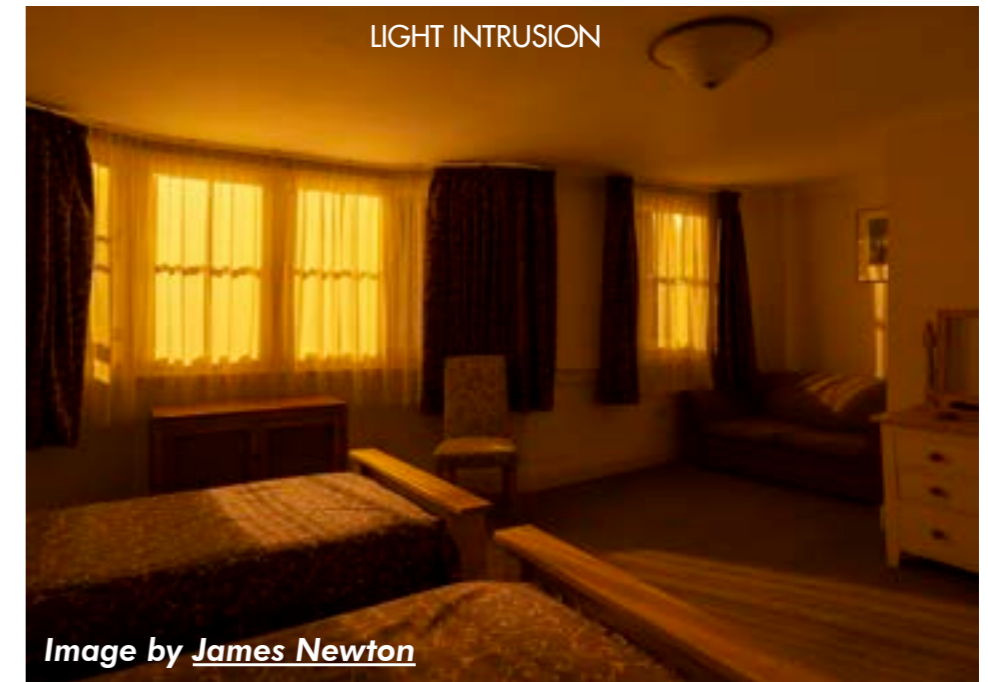

Light Intrusion (or spill) is when light extends into an area where it is not wanted, for example, into surrounding properties or nearby window(s). Lights should be installed correctly to reduce the spill of light beyond that of the required task area. Prevent light spill into areas that should not be lit, such as priority wildlife habitats like hedgerows, ponds/lakes/rivers and wetlands, species-rich grassland, salt marshes/estuaries, or roosting, breeding and foraging sites for sensitive species.

Within intrinsic dark landscapes the presence of any artificial lighting can be seen as obtrusive to the viewer.

Excessive illuminance is harsh and dazzling to many groups, including the elderly and light sensitive (photophobic) people. Often it can cause high contrasting areas of light, casting shadows that affect people’s perceptions and feelings of safety.

Planning Process:

The installation of lighting is frequently considered in isolation, rather than as part of wider planning goals or community visions, leading to:

- The gradual, incremental accumulation of lighting eroding the aesthetic quality and character of places and landscapes, as well as harming biodiversity and human health; and
- Poorly thought out designs that add to visual clutter and increasing levels of sky glow.

The planning process is the mechanism through which to look at places, sites and proposals holistically and take into account the full range of economic, environmental and social considerations. Yet lighting is all too often an after-thought in planning application process, resulting in more costly and poorly designed retro-fitted lighting installations after the completion of developments. A key aim of this TAN is to reverse this trend and support planners in delivering lighting best practice.

The NPPF (2025) states that planning policies and decisions should ensure that development "... limits the impact of light pollution from artificial light on local amenity, intrinsically dark landscapes and nature conservation". [National Planning Policy Guidance \(NPPG\) on light pollution](#) contains further details on light pollution considerations within the planning system. Whilst acknowledging the wider benefits of artificial light, it recognises that it is not always necessary, and has the potential to contribute to 'light pollution' and 'obtrusive light'. For maximum benefit and minimum harm, it recognises that "it is important to get the 'right light, in the right place and for it to be used at the right time'". The NPPG also recognises that since it can be costly and difficult to change lighting installations, meaning getting the design correct at the planning stage is important.

The TAN will support the implementation of multiple Local Plan policies (see [page 42](#)) and will also help to inform new, stronger policies when current local plans are next reviewed.



Implementation – Planning decision-making:

Even where planning consent is not required, those engaging with the local authority when seeking to install new lighting or replace existing should be encouraged to follow the Good Lighting Principles.

Where permission is required, this TAN will require lighting details to be submitted with planning applications, prior approval notification applications and other relevant consents (e.g. Advertisement Consent for illuminated signs), both within the plan(s) and drawings, and within design and access statements.

All applications for proposals that involve the installation of external lighting (including replacement lighting) will need to complete and submit the Good Lighting Checklist on [page 54](#).

In the case of applications that involve significant lighting and/or extensive glazing, the following section 'Lighting Design Process' sets out the baseline assessment, design process and information to be submitted.

The level of information required will be proportionate the scale of the lighting proposed, making sure the Good Lighting Principles are met (see [page 6](#))

Compliance and Monitoring:

Conditions should be applied to outline and full planning, prior notification and other consent approvals as relevant to ensure that lighting is installed in accordance with the approved designs, layout and specifications. Some examples of model planning conditions are contained in [Appendix 6.4](#). For applications involving significant lighting installations and/or extensive glazing, a post operational monitoring site visit will be conducted to check that conditions are being complied with.

An informative can also be used to direct applicants to the Cumbria Good Lighting Technical Advice Note.

Local planning authority Compliance and Enforcement Officers will check for compliance with lighting conditions and address any breaches of consent.

Where lighting causes a nuisance under [Section 102 of The Clean Neighbourhoods and Environment Act 2005](#), Environmental Protection Officers can assess the impact on neighbouring premises and instruct changes to the lighting.

Local planning authorities should be monitoring progress on reducing light pollution as part of their Environmental Outcome Reporting. This is best achieved through a combination of satellite online data and ground-truthing using Sky Quality Meters (SQMs), both hand-held and fixed devices. (See [page 14](#) for details)

Road & Footway Lighting:

Road or Footway lighting to be adopted by the local authority will need to comply with the design and specification requirements of the adopting authority in the relevant Design Guide(s). These requirements take into consideration lighting best practice, the good lighting principles in this TAN and community feedback through the planning application process.

In respect of road and footway lighting to be adopted, the Highway Authority, will enter an Agreement with the developer and ensure compliance.



1) Lighting Justification

- What is the lighting needed for? Provide a statement clearly justifying the purpose and specific task(s) or function(s) for the proposed lighting:

The purpose of the artificial lighting should always be clearly defined and must be provided for a specific purpose, e.g., to illuminate a given area, to mark out pathways, to highlight obstacles or objects of interest within an area. Clearly, the effectiveness of the installation can only be measured after the purpose is defined, and this should be the starting point of any design.



2) Baseline Lighting Survey Information

- **Current site** - What lighting is currently on the site? How is it used and what for? Is there potential to improve existing lights to achieve a net reduction? Identify any sensitive features or areas. Take account of seasonality variations, ie. when less leaves over the winter months when the length of days is shorter.

- **Survey of site and it's surrounding area at night – What is the surrounding lighting environment?**
See the next page for assessment examples.

- **Environmental Zones** – The use of this Environmental Zone typology is commonly applied, but it should not override the circumstances of each individual site, nor Cumbria’s net light pollution reduction goal. Light pollution if not confined by settlement limit boundaries, and the light pollution map of Cumbria clearly shows the extent of sky glow and obtrusive light cutting across urban and rural areas (See the table below shown for reference).

- **What is the lighting needed for?** Provide a statement clearly justifying the purpose and specific task(s) or function(s) for the proposed lighting:

The purpose of the artificial lighting should always be clearly defined and must be provided for a specific purpose, e.g., to illuminate a given area, to mark out pathways, to highlight obstacles or objects of interest within an area. Clearly, the effectiveness of the installation can only be measured after the purpose is defined, and this should be the starting point of any design.



3) Lighting Impact Assessment

- Study of area surrounding site to determine impact of lighting on humans, fauna, flora, landscape and the night sky:
- Identify locations, viewpoints or public highways nearby where lighting and/or light spill could be a direct (in view) or indirect visual nuisance (note topography, vegetation);
- Identify wildlife habitats and sensitive sites for species;
- Identify adjacent or nearby dark landscapes or green spaces;
- Is there a Landscape and Visual Impact Assessment (LVIA) included in the application and if so, does it cover darkness, tranquillity, night-time views and the impact/potential impact of lighting?

Explain how the lighting makes a positive contribution to the 5 Good Lighting Outcomes (See page 9), and list any mitigation measures:

Energy & Carbon Savings	
Attractive and Safe Spaces	
Amenity and Well-Being	
Enjoying Dark Skies Heritage	
Protecting Biodiversity	

Zone	Surrounding	Lighting environment	Examples
E0	Protected	Dark (SQM 20.5+)	Astronomical Observable dark skies, UNESCO starlight reserves, IDA dark sky places
E1	Natural	Dark (SQM 20 to 20.5)	Relatively uninhabited rural areas, National Parks, Areas of Outstanding Natural Beauty, IDA buffer zones etc.
E2	Rural	Low district brightness (SQM ~15 to 20)	Sparse inhabited rural areas, village or relatively dark outer suburban locations
E3	Suburban	Medium district brightness	Well inhabited rural and urban settlements, small town centres of suburban locations
E4	Urban	High district brightness	Town / City centres with high levels of night-time activity

Extract from **ILP GN01 The Reduction of Obtrusive Light - Environmental Zones Diagram**

The sky quality condition of the area where the development is planned to take place must be conveyed. There are various ways to define the sky quality:

Option 1 - Go to www.lightpollutionmap.info or any similar light pollution map platform. Search & find the relevant location. Left click to see the SQM value. Take a measurement from each shade of colour.

Option 2 - Use a sky quality meter on a clear night (with no moon) to map out the area with multiple readings. Include the readings in the submission to identify the baseline sky quality (See [page 43](#) for precedent).

Option 3 - Most accurate & sophisticated method is to use automated SQM readers which take zenith photos. Learn more [here](#).



BORTLE SCALE	1	2	3	4	4.5 - 5	6	7	8 - 9
SKY QUALITY	Excellent	Truly Dark	Very Good	Good	Fair	Poor	Very Poor	Bad
SKY BRIGHTNESS (SQM mag/arcsec ²)	>21.9	21.9 - 21.5	21.5 - 21.3	21.3 - 20.8	20.8 - 19.1	19.1 - 18.0		<18

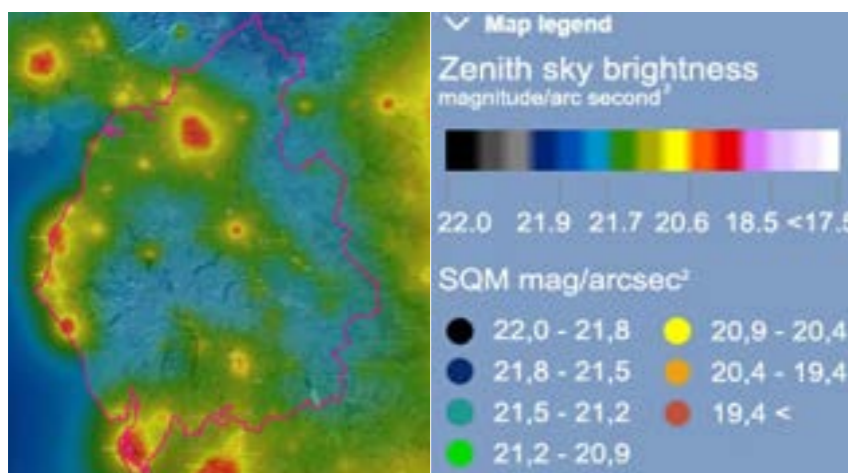

Option 1 (Acceptable)
Satellite imaging showing indicative sky brightness.
*Please note that the SQM readings & VIIRS satellite imaging shown on the www.lightpollutionmap.info are not precise. It is advised to assume that the actual condition is slightly worse than what's shown on any light pollution map platform.



Option 2 (Better)
Hand-held SQM reader.
(See [page 43](#))

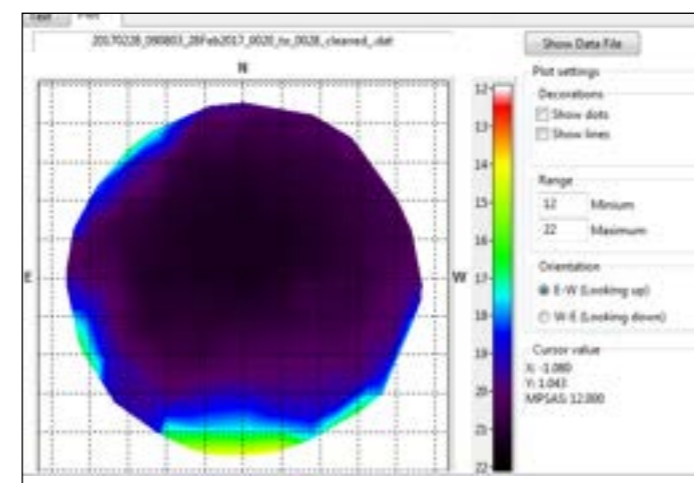

Option 3 (Best)
Automated SQM reader with zenith photos, radiance or luminance imaging & readings. Image courtesy of Brian Espey. Learn more [here](#).



Option 4 - LUX & CCT readings
*If the site is already illuminated.
(See [page 44](#))

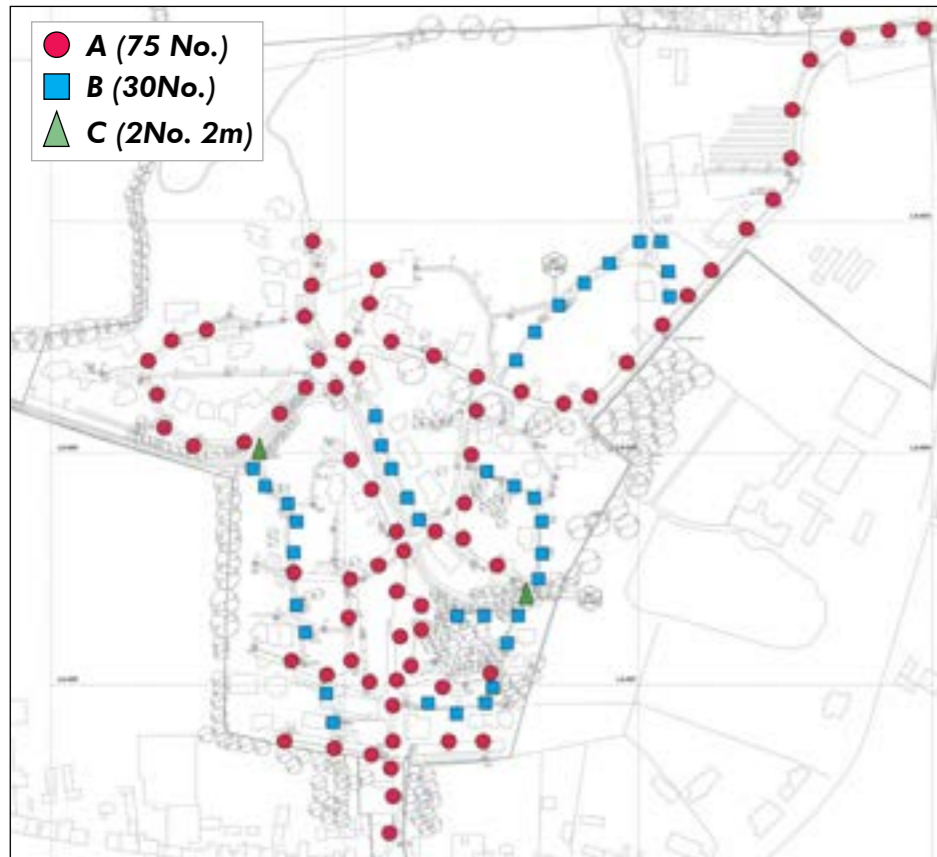

4) Lighting Layouts



1) Legible & scaled plan(s) are required to indicate the proposed position of all external luminaires (Referenced to the Lighting Equipment Schedule).

(See page 46 for detailed information).

5) Lighting Equipment Schedule

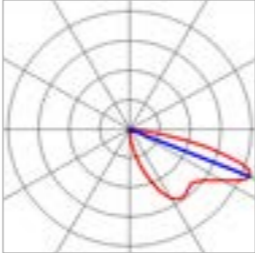
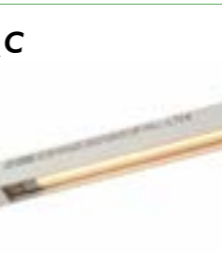
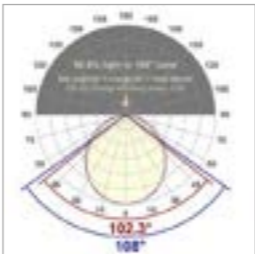
 <p>● A</p>		<ul style="list-style-type: none"> • 2200K • 26W • 3583 lumen • 137lm/W • CRI 70 • Dimmable • DALI
 <p>■ B</p>		<ul style="list-style-type: none"> • 2200K • 5W • 496 lumen • 99.2lm/W • CRI 80 • Dimmable • PIR sensor
 <p>▲ C</p>		<ul style="list-style-type: none"> • 2200K • 9.3W/m • 810 lumen/m • 87 lm/W per m • CRI 90 • Dimmable • PIR sensor

2) An equipment schedule providing the specification for all sources, luminaires & accessories. To include manufacturer and model description(s), dimensions (size & weight), lumen output, colour temperature, wattage power & efficiency, mounting, drivers and all accessories and associated columns/bracketry. See below for the breakdown list:

- Manufacturer & Model
- Luminaire Image & Drawing
- Absolute photometry (Beam distribution)
- Dimensions
- Colour temperature
- Wattage
- Lumen output
- Efficiency
- Colour-rendering
- Dimmability
- Means of control
- Adjustability
- Accessories

(See page 47 for detailed information).

6) Lighting Details

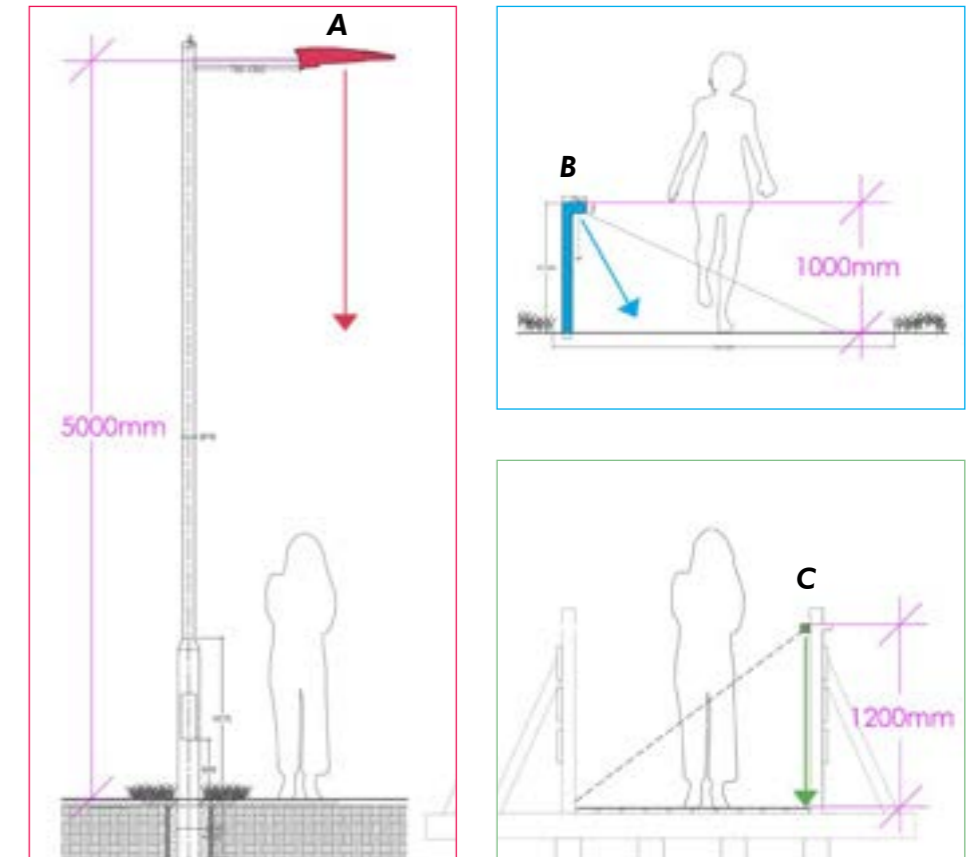

3) Section & elevation drawings showing mounting height, method, types, height, tilt angles & direction for all luminaires and associated equipment on the building(s) or within the site.

(See page 48 for detailed information).

7) Calculations

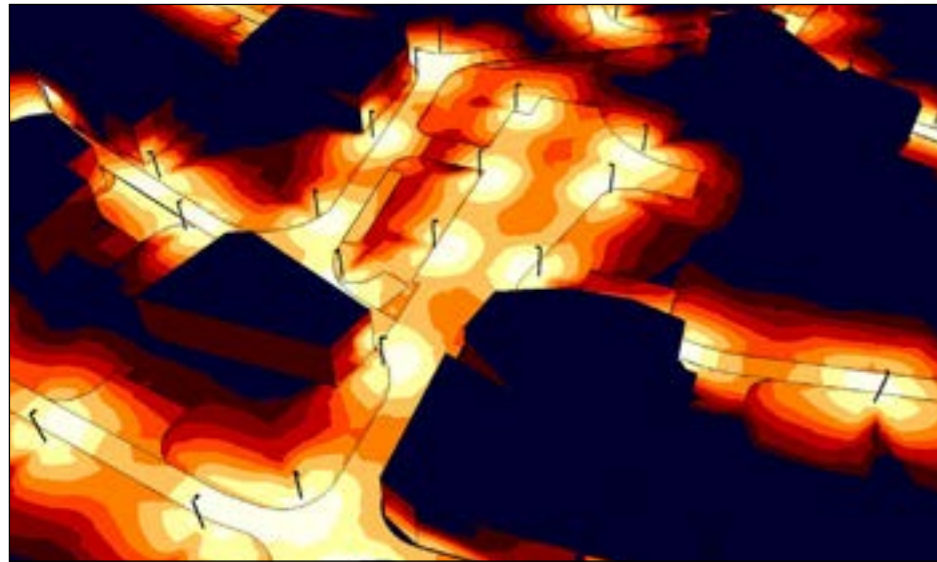

0.01	0.1	1	2	4	8	16	32	100
Illuminance [lx]								
Illuminance			Eav			5.9 lx		
Average illuminance			Emin			1.8 lx		
Minimum illuminance			Emax			13.3 lx		
Maximum illuminance			Emin/Em			1:3.33 (0.3)		
Uniformity Uo			Emin/Emax			1:7.51 (0.13)		
Diversity Ud								

Indicative calculation example

4) Calculations showing typical details lighting illuminance contours (lux) clearly indicating extent of lighting on horizontal and vertical planes to show the impact within the site, on buildings and surrounding landscape.

Details showing lighting calculations indicating illuminance and/or luminance, uniformity, maintained averages. Lighting standards are for guidance purposes - each lighting task and risk assessment should be tailored to every individual site.

If you don't know what lux levels to aim for, you can refer to the British Standards for guidance as per your specific development type. Clarify if the project is expected to meet certain lighting standards or regulations. If not, all projects are encouraged to use light judiciously.

(See [pages 47-48](#) for detailed information).

8) Design Details & Mitigation Considerations



Automated blinds

Shield for existing lanterns

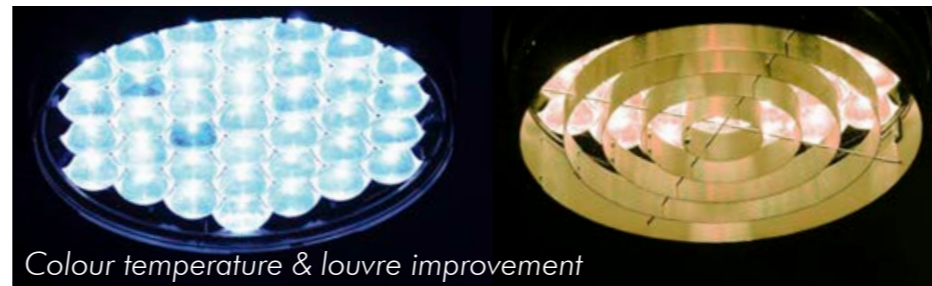

Colour temperature & louvre improvement



PIR Sensor

Timer

Photocell Sensor

Re-lamping

5) Drawings, where relevant, showing glazed openings on elevations or from roof lights. Convey what measures were taken, opportunities were found in order to reduce the overall light pollution level.

Compare with the baseline site and surrounding area survey; include additional mitigation measures as appropriate, such as shielding, baffles, louvres, Infra-red CCTV, shutters and electrochromic or tinted glass. Does the lighting still represent a significant cumulative increase of intrusion into a dark landscape? Consider alternatives to the whole design.

(See [page 49](#) for quick ways to improve the existing lighting).

Glazing Design Principles:

- a) Any glazing of 10m2 or more requires a VLT (Visible Light Transmission) calculation as part of the application.
- b) A maximum target upper VLT limit of 0.65 +/-0.05 should be applied in all glazing applications, regardless if the internal illumination is low enough to suggest higher light transmission values.
- c) Avoid large single continuous areas of glazing such as multi-floor to eaves glazing/barn door openings or single elevations.
- d) Should not be on roofs or ceilings without sufficient mitigation.
- e) High impact commercial Greenhouses should be avoided.

9) Control System & Operation

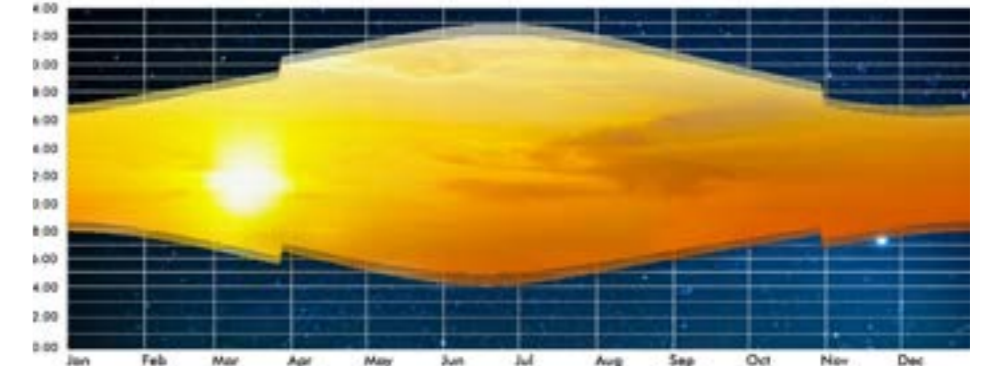

Daylight diagram

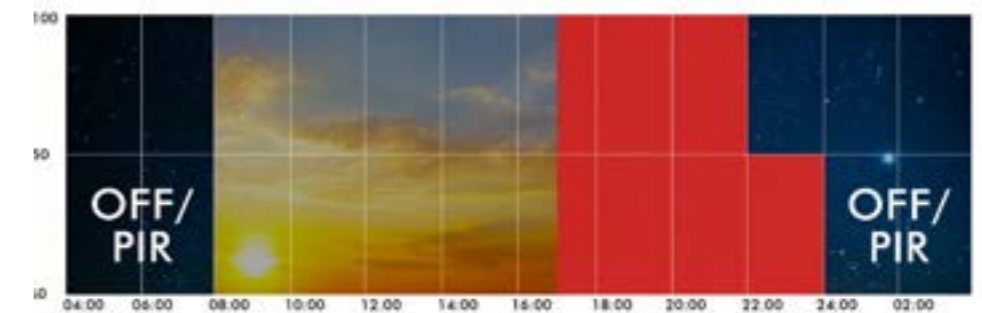

Winter dimming profile example

6) Manual or automated, all lighting schemes should employ a variable dimming or curfew regime to suit different needs during the night. Dawn to dusk continuous all-night lighting is a waste of electricity in the context of urgently needing to reduce our carbon emissions, and adds stresses onto already fragile levels of biodiversity. The best light to protect dark skies, is a light that isn't on. The degree of night-time darkness throughout the year will vary according to the angle of the Sunlight below the horizon. Around midsummer, for example, it never gets truly dark whereas during the peak astronomy observation season in winter, requiring earlier times on lighting controls.

Dimming is a key feature offered by the LED technology. When used right, dimming can help reduce skyglow, energy usage & the impact on flora and fauna whilst prolonging the lamp life. Lights should still be extinguished as early as possible when no longer required or at the end of business hours. Public street lighting is already dimmed in most cases across Cumbria, and in rural communities switch-offs (100% dimming) are increasingly supported (usually from 11-12pm to 6am). Each application should include their lighting control rationale in responding to: early evening, late night and the curfew times. Details such as when the lights are switched on and off, if dimming or presence detection sensors (PIRs) are used, whether a central management system or a manual control method is proposed should be submitted all together with the envisaged illuminance levels & timings.

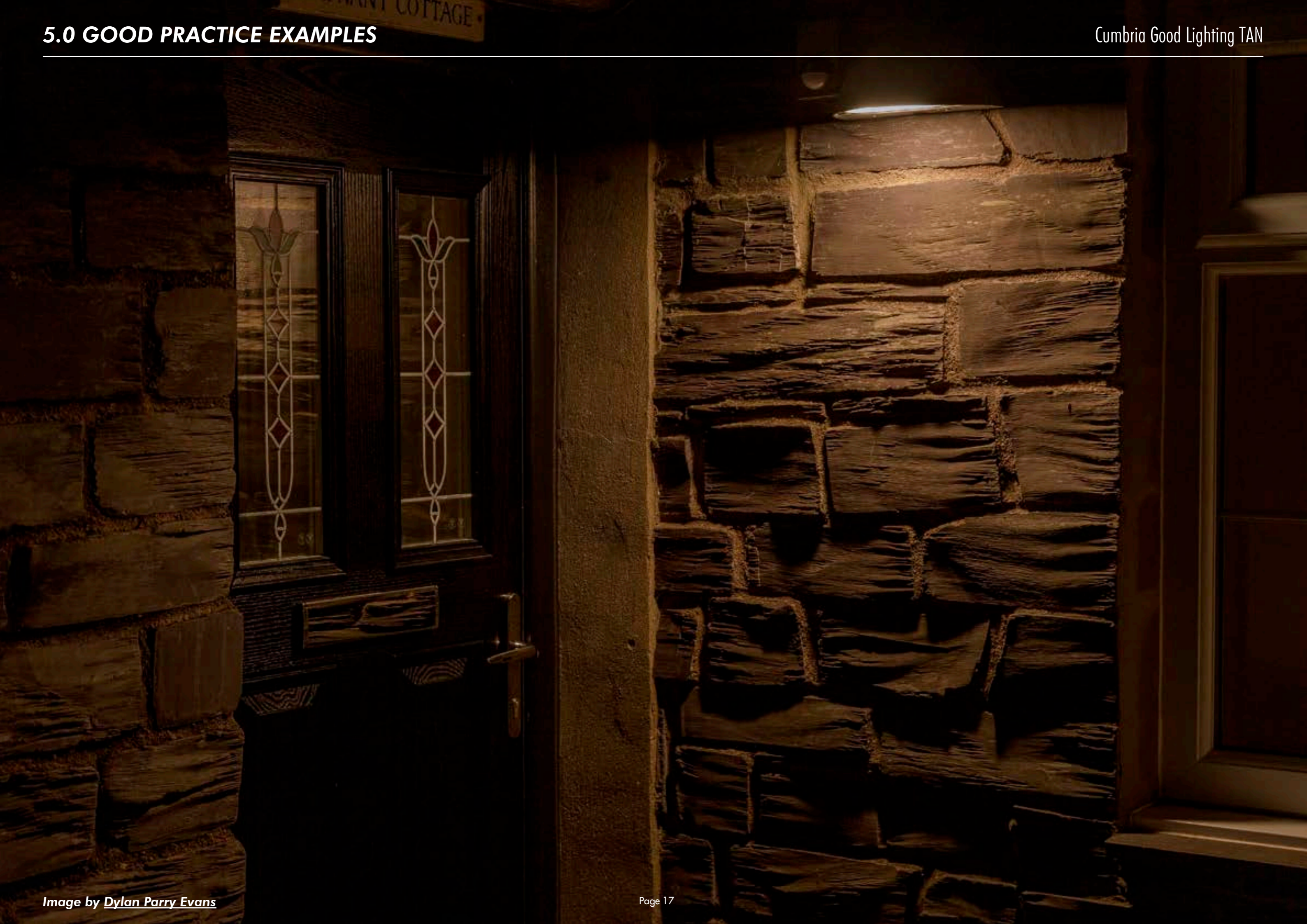

There are clear causes of light pollution & simple ways to eliminate it:

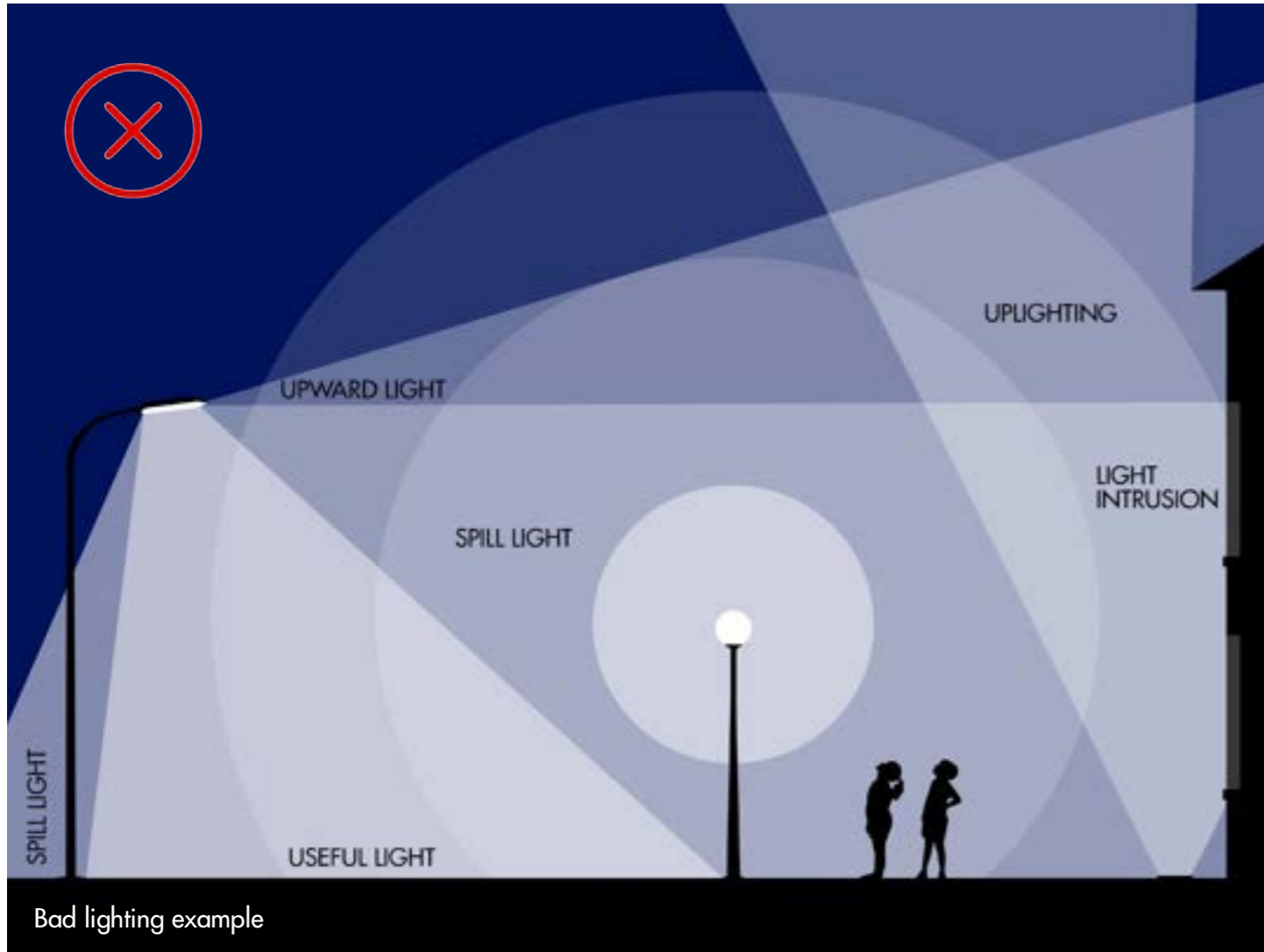

Light pollution & nuisance is caused by the factors listed below:

- Light going upwards.
- Light trespass into or out of the houses.
- Use of cool colour temperatures.
- Unshielded & glary lighting.
- Intense light which gets reflected from the floor plane.

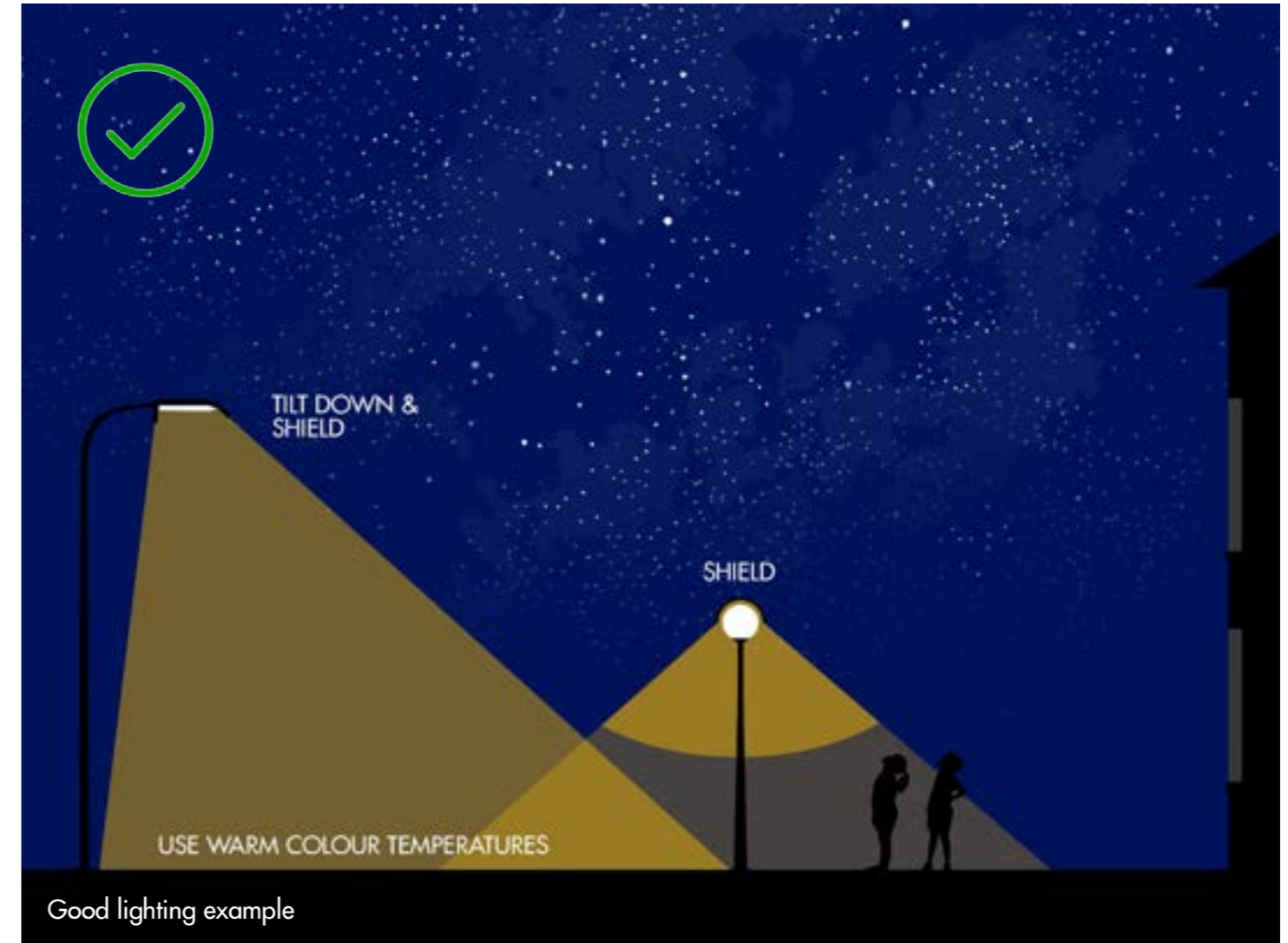

Light pollution can be eliminated through the measures below:

- Use the light where it is needed & in the amount it is needed.
- Shield the light and do not allow it to go upwards or sideways.
- Reduce glare through accessories or using the correct light distribution.
- Use of warm colour temperatures.
- Utilise dimming profiles, timer (astronomical clock), photocell, lighting control systems or PIRs.

- Use lower mounting level and do not illuminate a large area with a single source. This will result in a steep tilt angle causing glare and light pollution.
- Distribute the task between multiple down-facing luminaires. As long as the quantity is not excessive, using multiple luminaires can be a helpful method for illuminating targeted areas without causing light spill & glare.

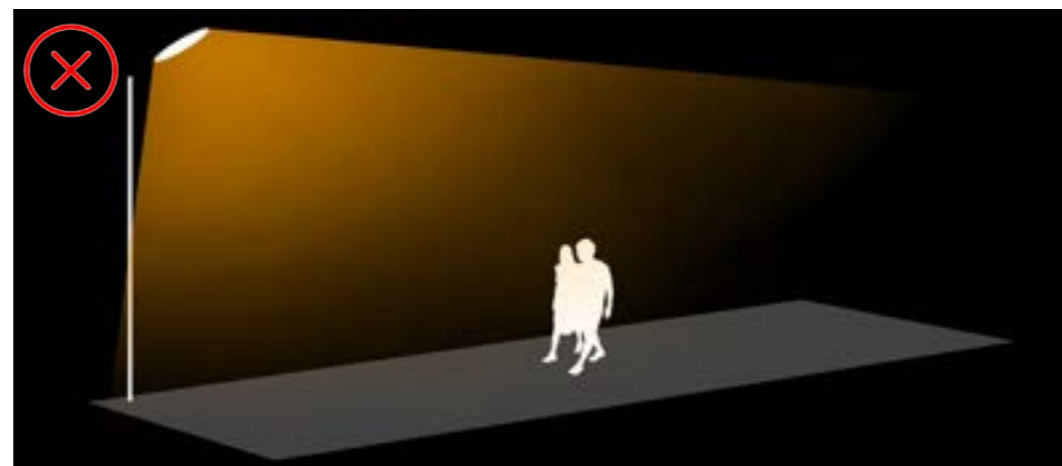

- Uplights can only be considered when the upward spill is contained.
- Building-mounted downlights can be considered to complement street lighting if they won't cause excessive illumination.



- Do not illuminate soft landscape & planting for decorative purposes. Do not use glowing or beacon lights.
- If you **are not expected** to meet a certain lighting standard, it is perfectly acceptable for the lighting effect to be intermittent & variable.
- If you **are expected** to meet a lighting standard, it would be helpful to achieve a certain level of uniformity. Uniformity means that the lowest level of light is higher than 0. Higher minimum lux value means higher uniformity level. **See page 48 for uniformity.**

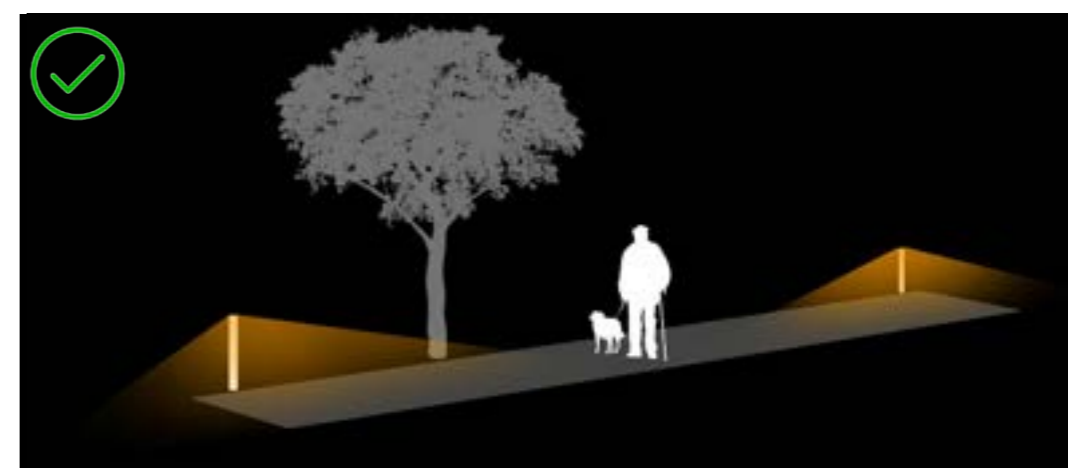

- Don't use luminaires which throw light above the horizon level. Use lights with 0 Upward Light Output Ratio.
- You can integrate and conceal the lighting elements within the existing & low level structures.



5.0 GOOD PRACTICE EXAMPLES/ PRECEDENTS



Vertical illumination achieved through downlighting

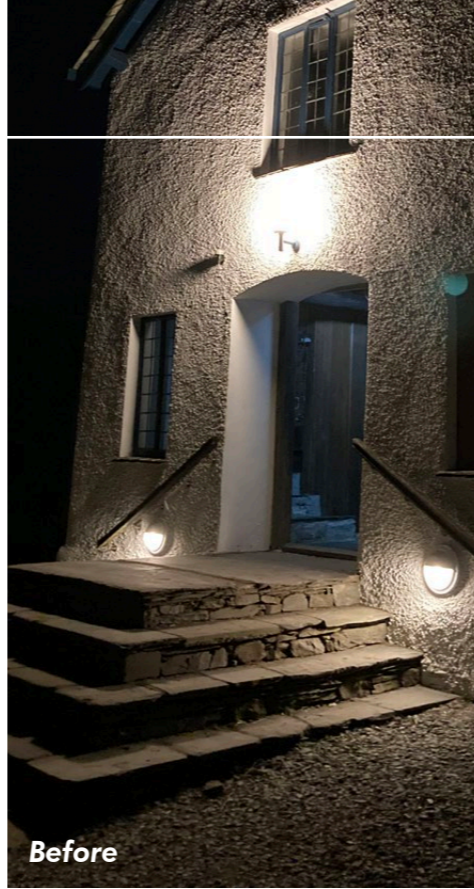

Before



After



Backlit signage with downlit car park wall.



Linear downlit sign



Spot downlit sign



Responsible industrial lighting

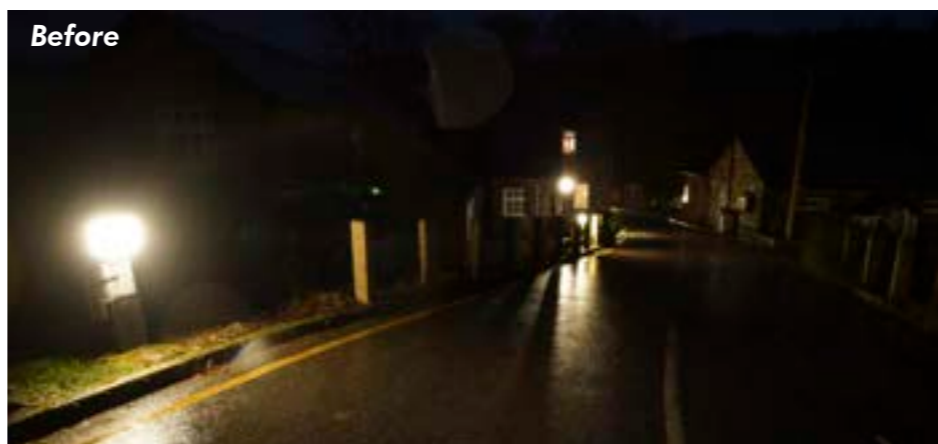

Before



After

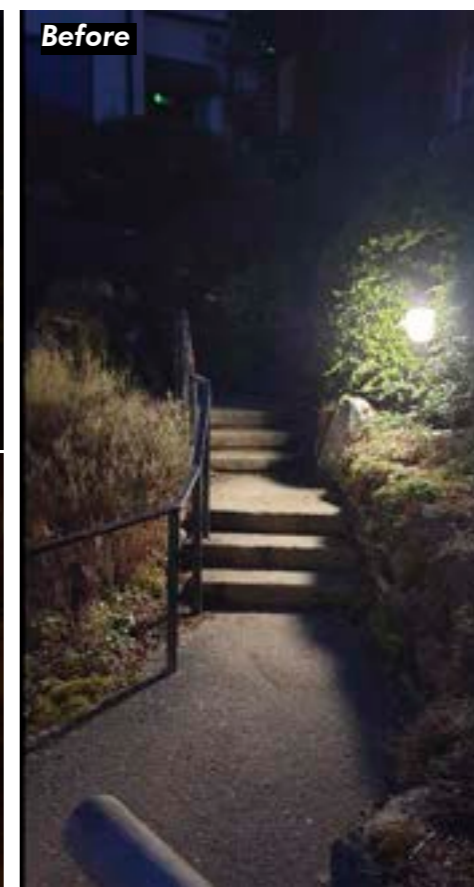

Before



After



Responsible sports lighting



Handrail-integrated lighting

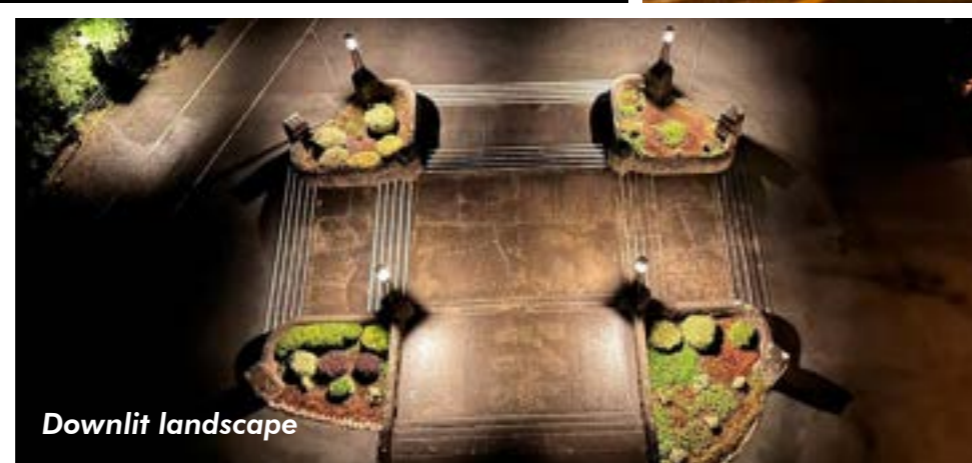

Downlit landscape



Before



After

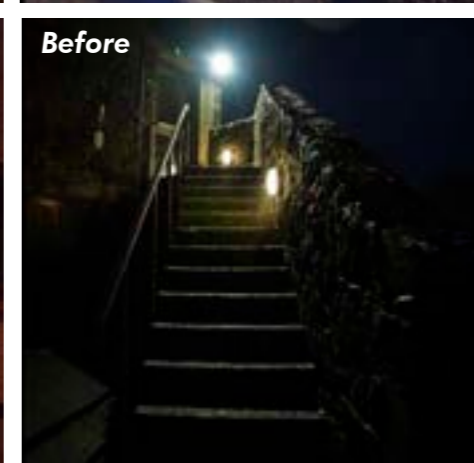

Before

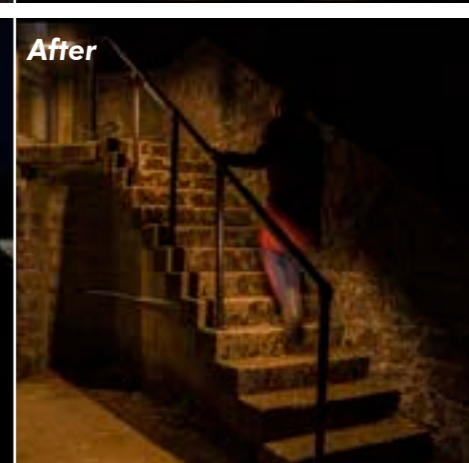

After

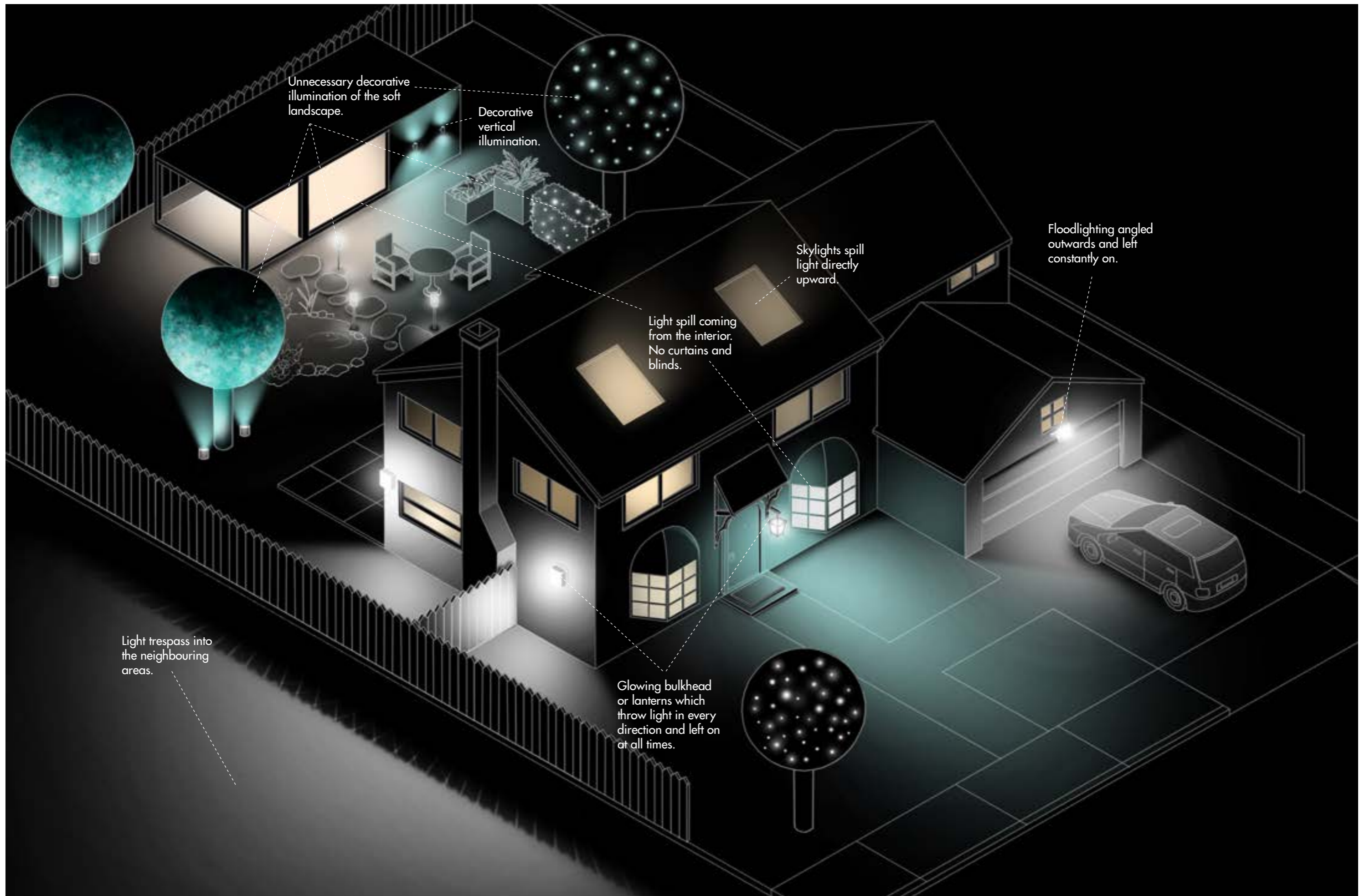

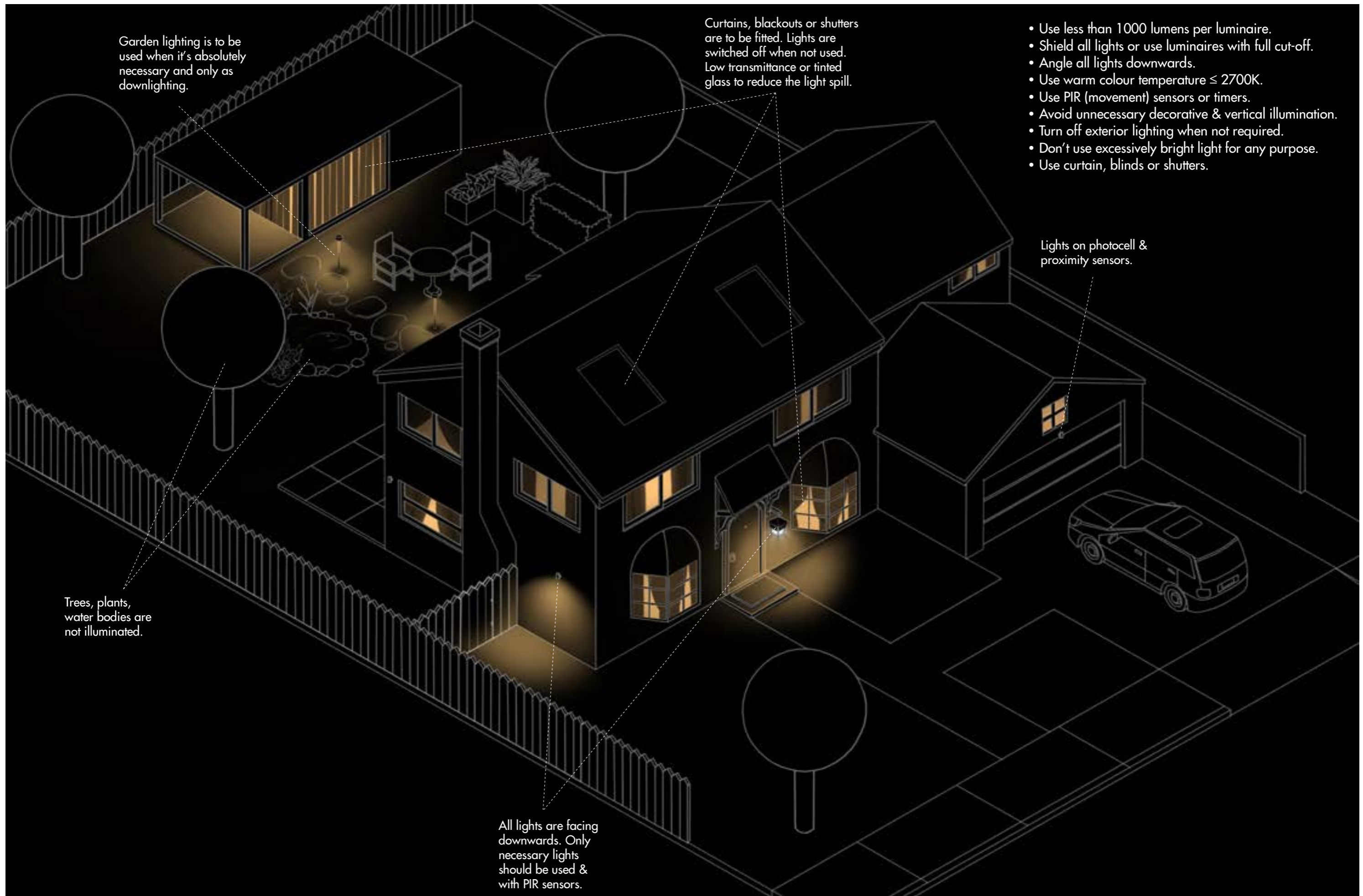

* Applies to all commercial establishments, pubs and small retails.

Light columns are angled upwards with unnecessarily high number of powerful luminaires.

Excessive landscape & decorative lighting with significant upwards output.

All signage are excessively illuminated.

Facades are uplit.



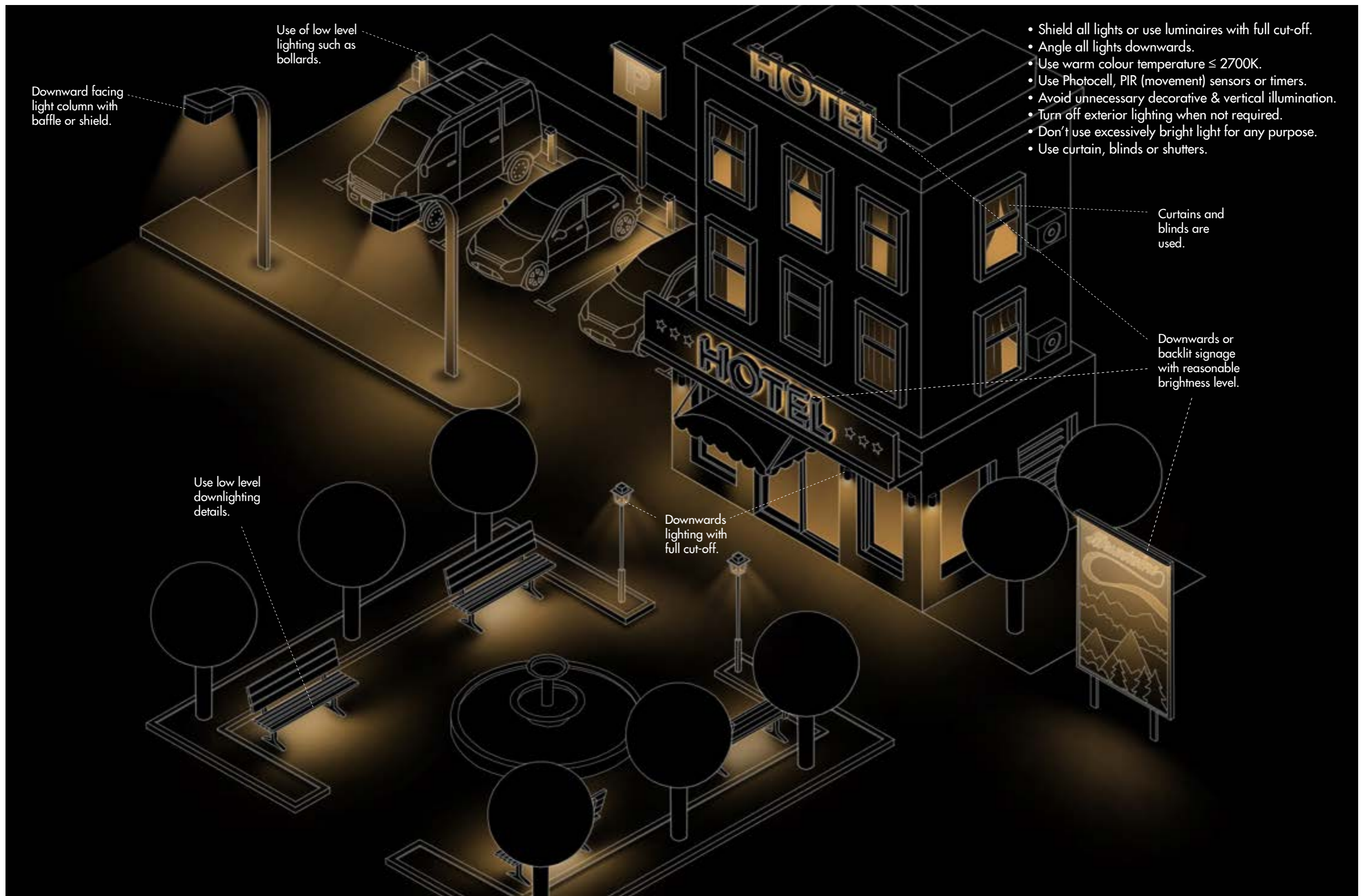

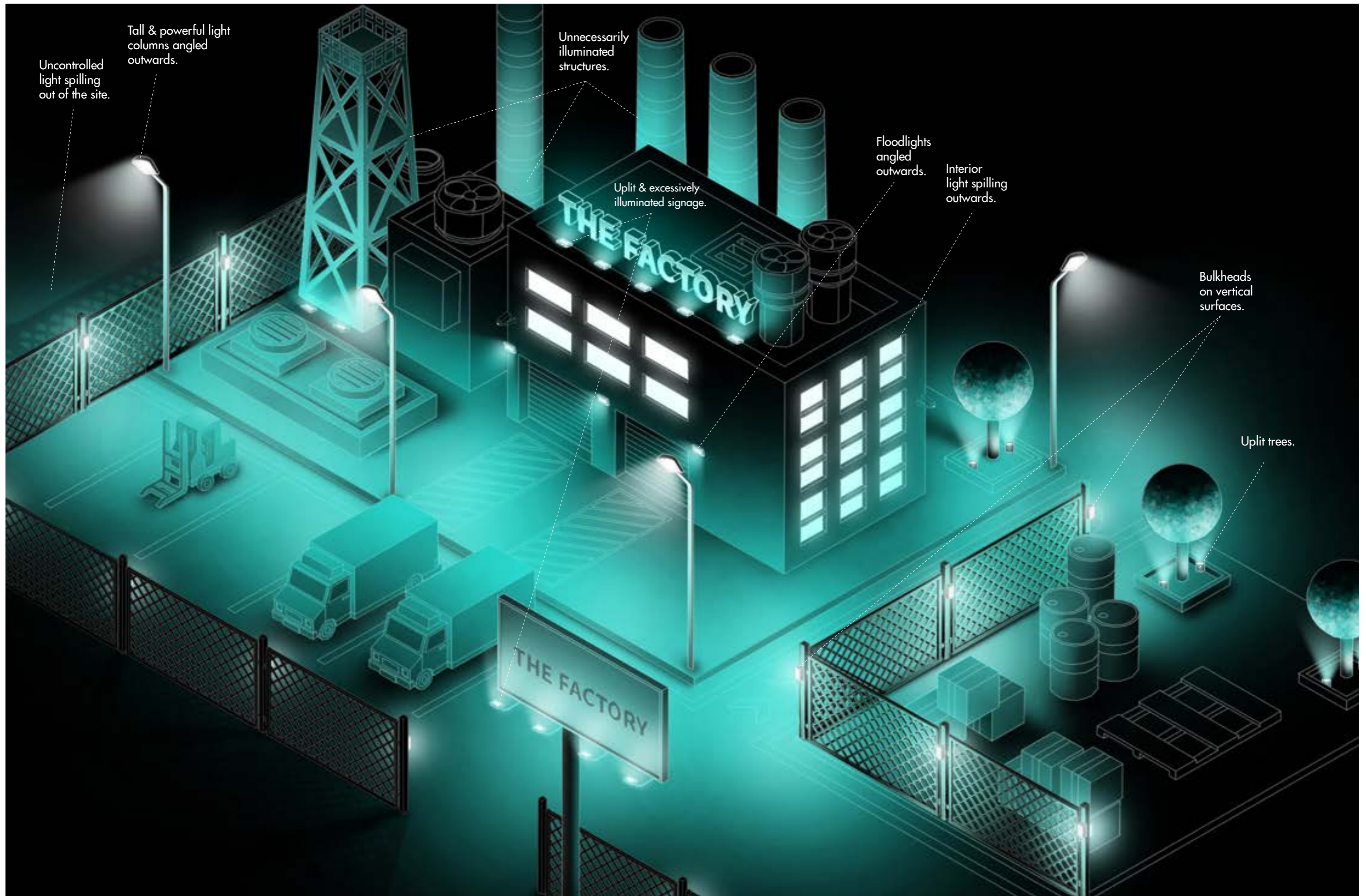

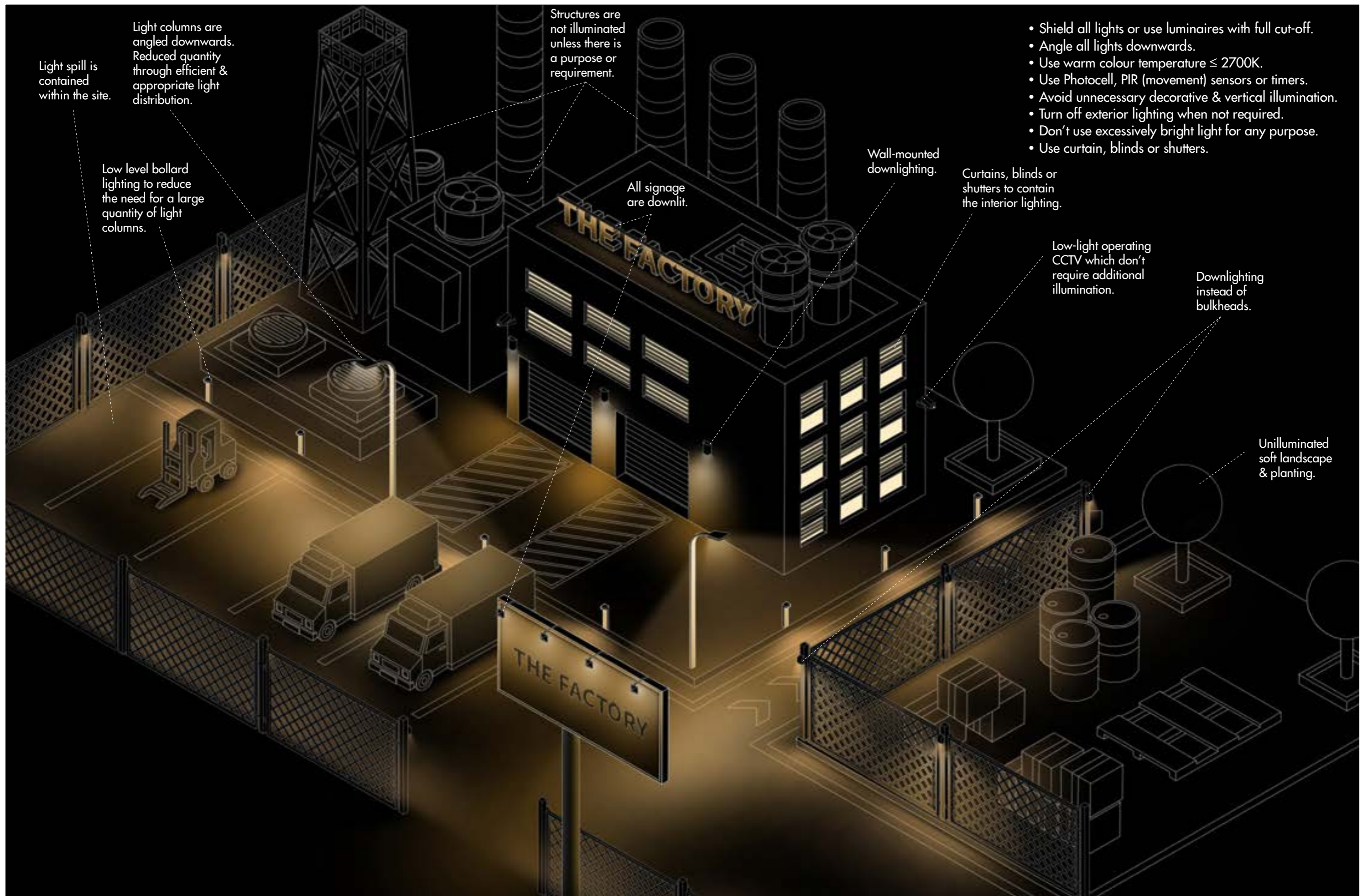

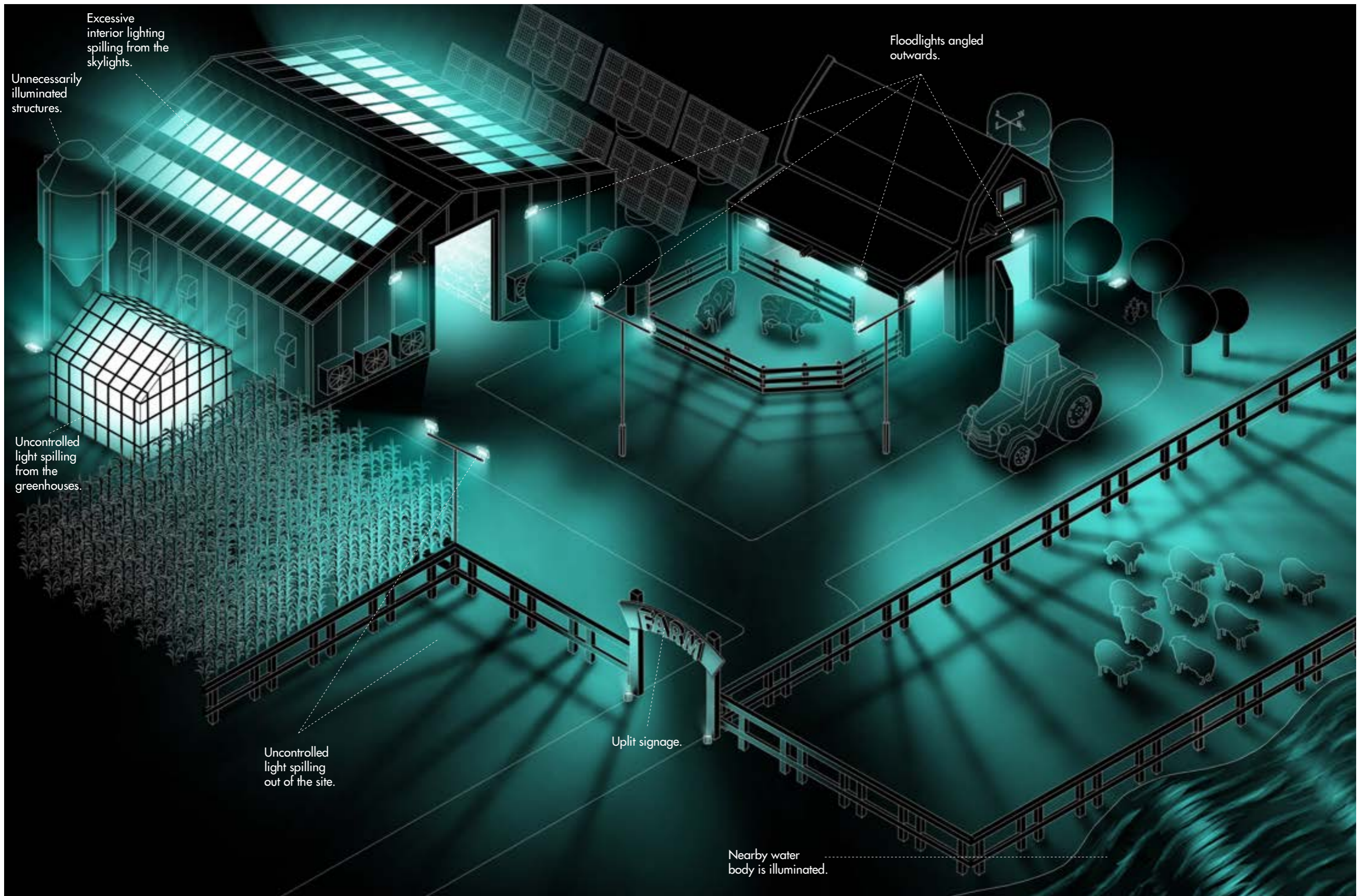

Excessive interior lighting spilling from the skylights.

Unnecessarily illuminated structures.

Uncontrolled light spilling from the greenhouses.

Uncontrolled light spilling out of the site.

Uplit signage.

Floodlights angled outwards.

Nearby water body is illuminated.

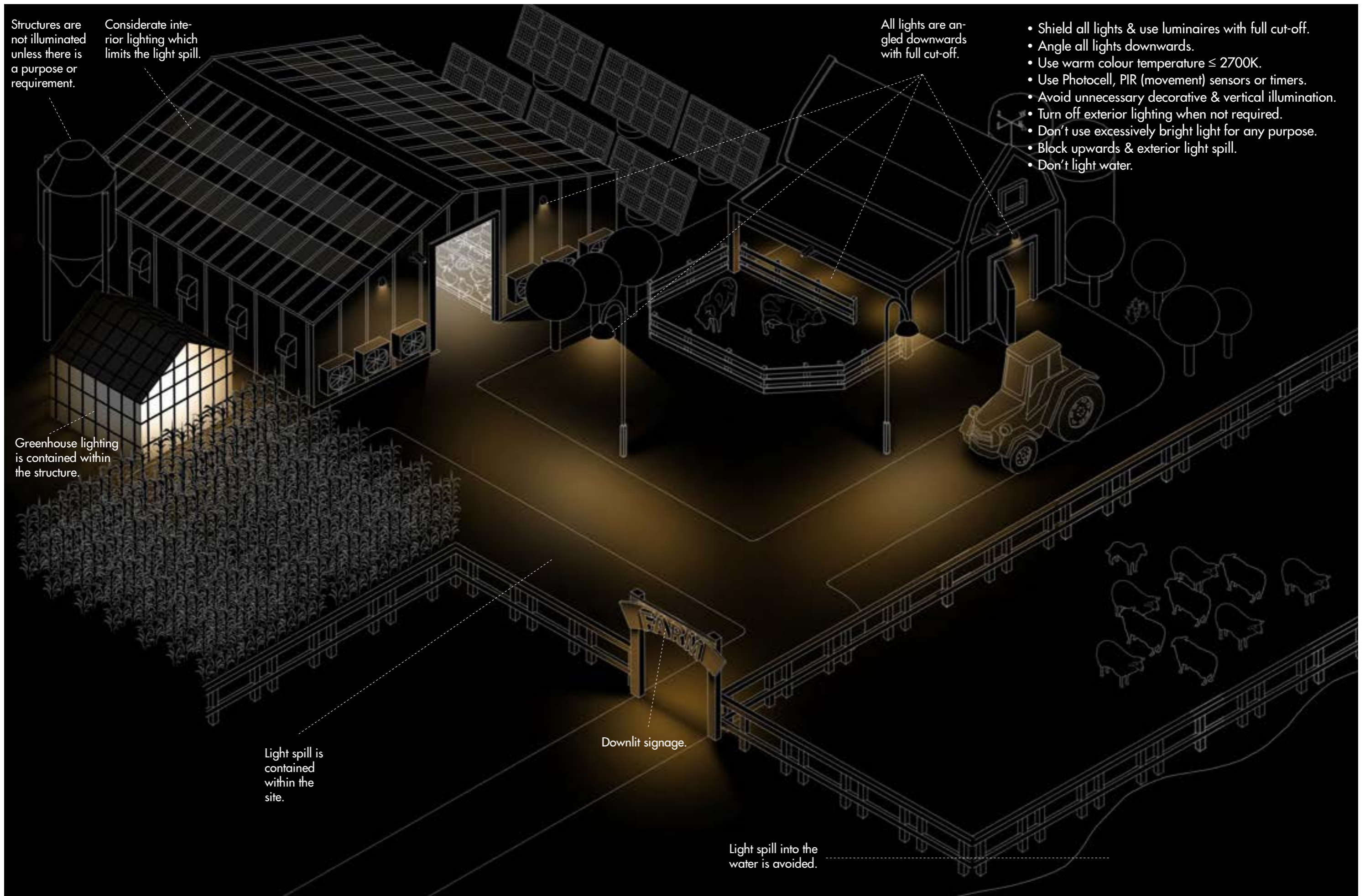

High quantity of unshielded, cool coloured luminaires angled above 70 degrees.

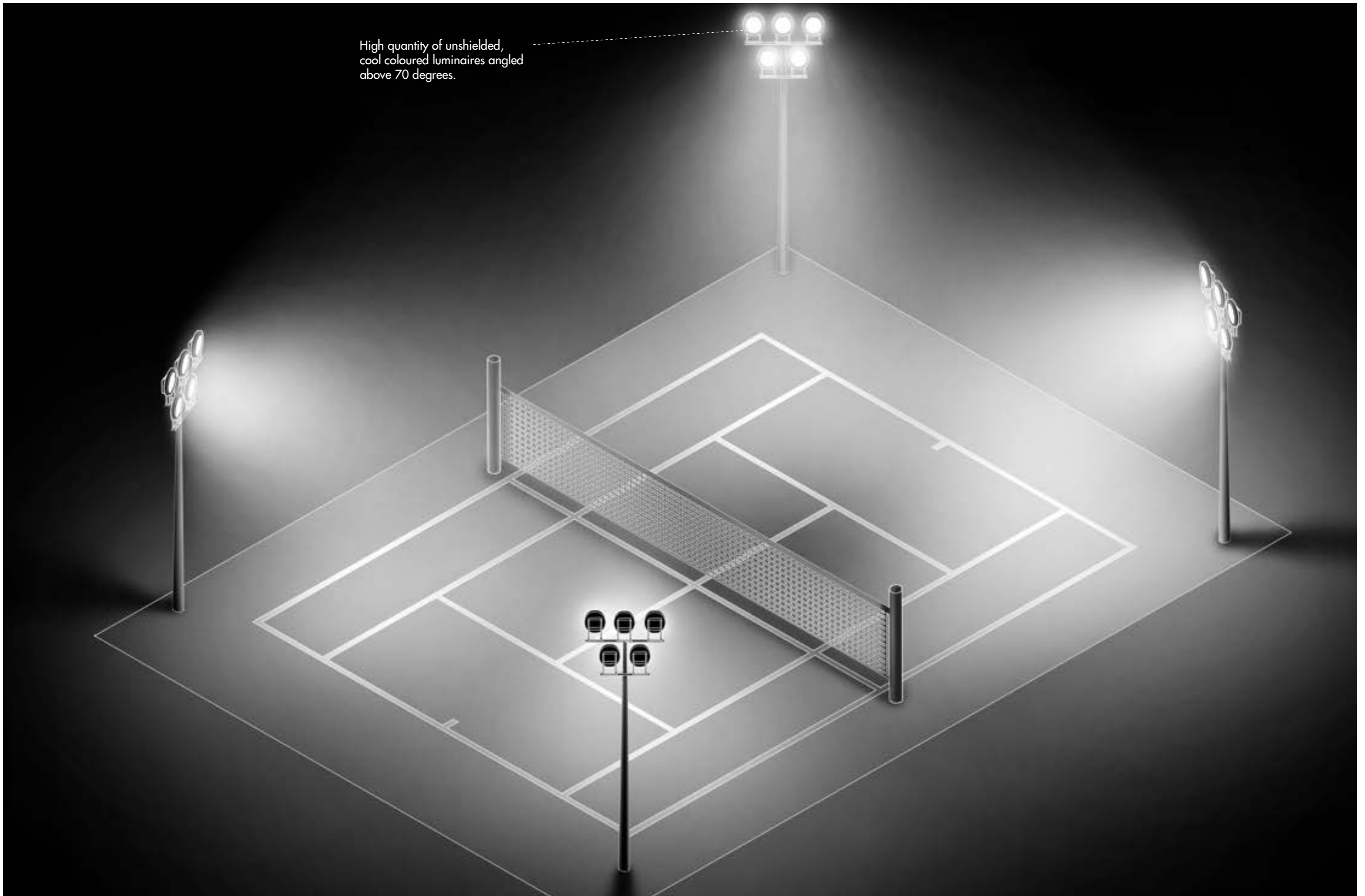

- Use baffles & shields to limit the light spill.
- Use gels/ filters to warm the colour temperature up.
- Angle the lights down.
- Reduce the quantity if possible.
- OR use the latest LED luminaires which can offer all of the above with less quantity.

- Shield all lights & use luminaires with full cut-off.
- Use warm colour temperature $\leq 3000\text{K}$.
- Design the lighting per field independent from the others.
- Avoid over-performing light levels. Only aim for the required level of light.
- Switch the lights off when the field is not used.

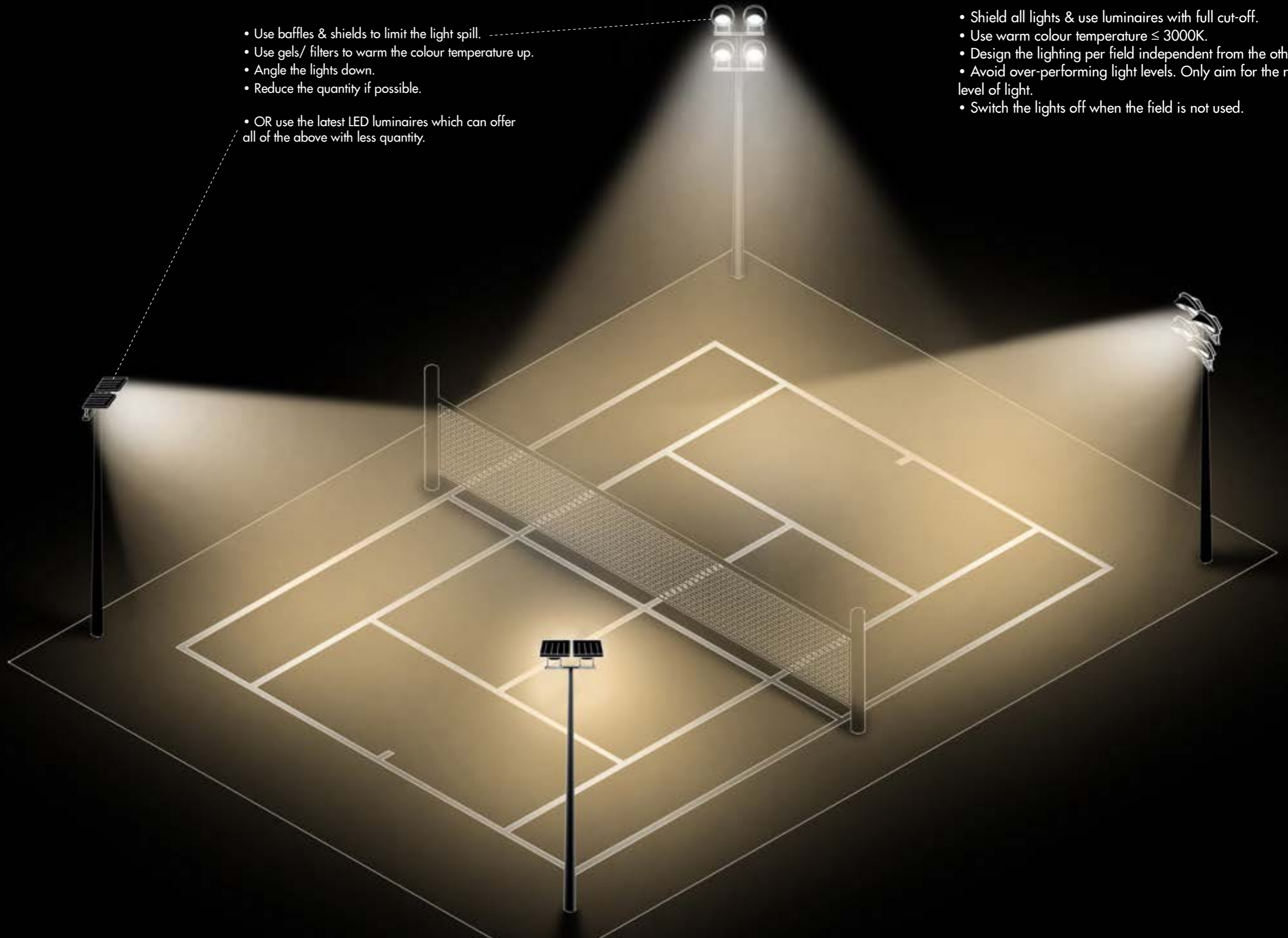

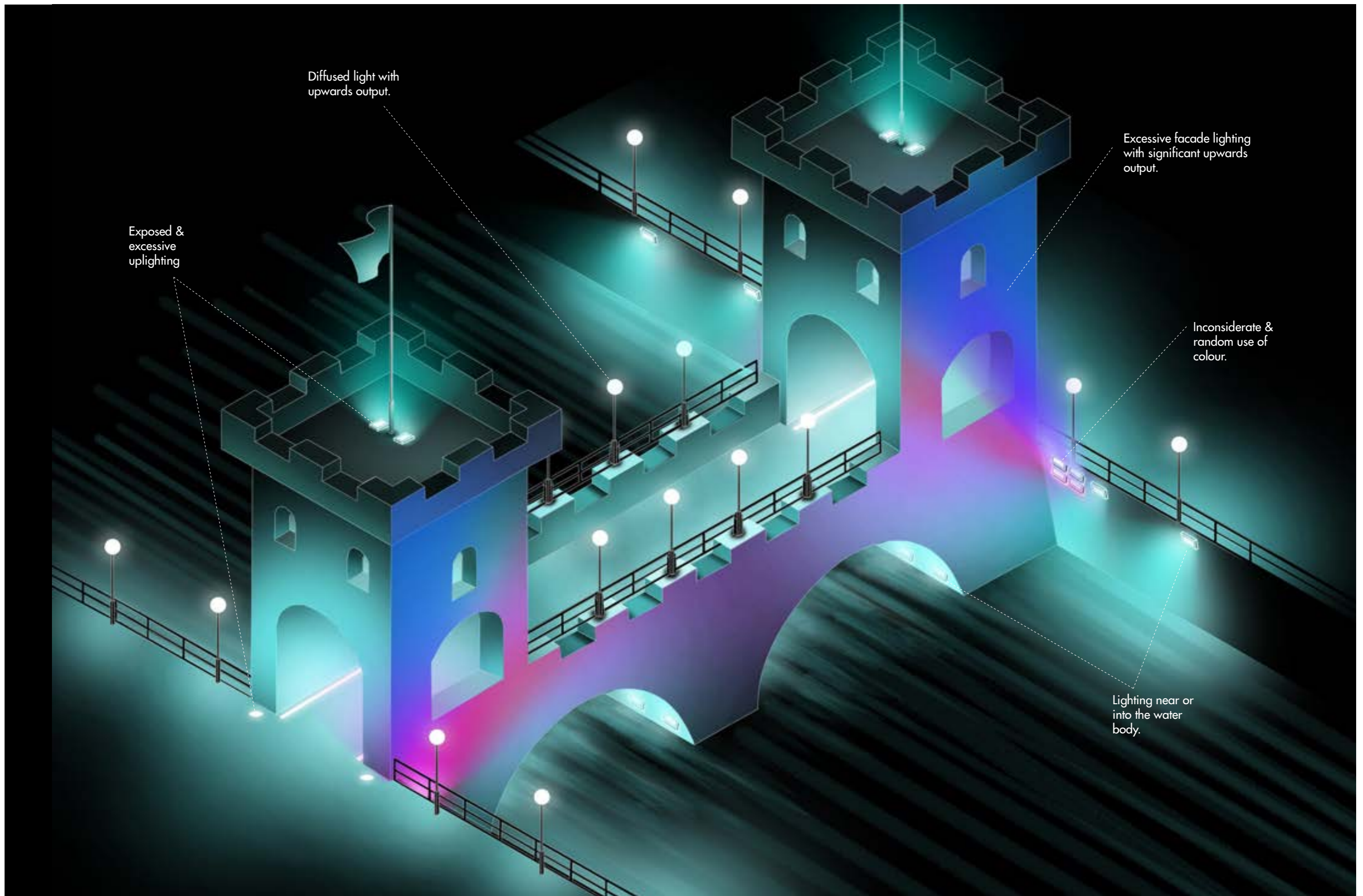

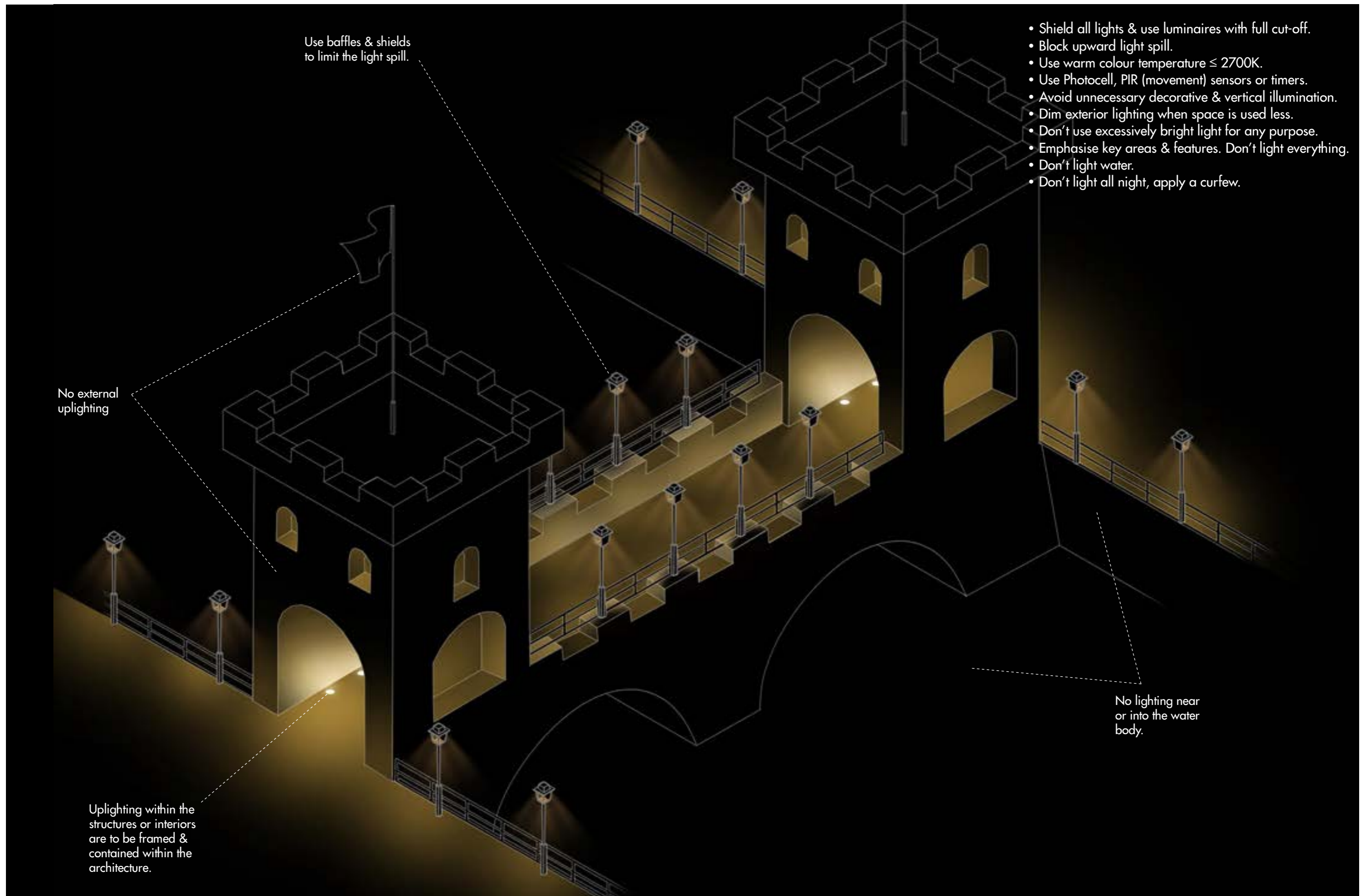

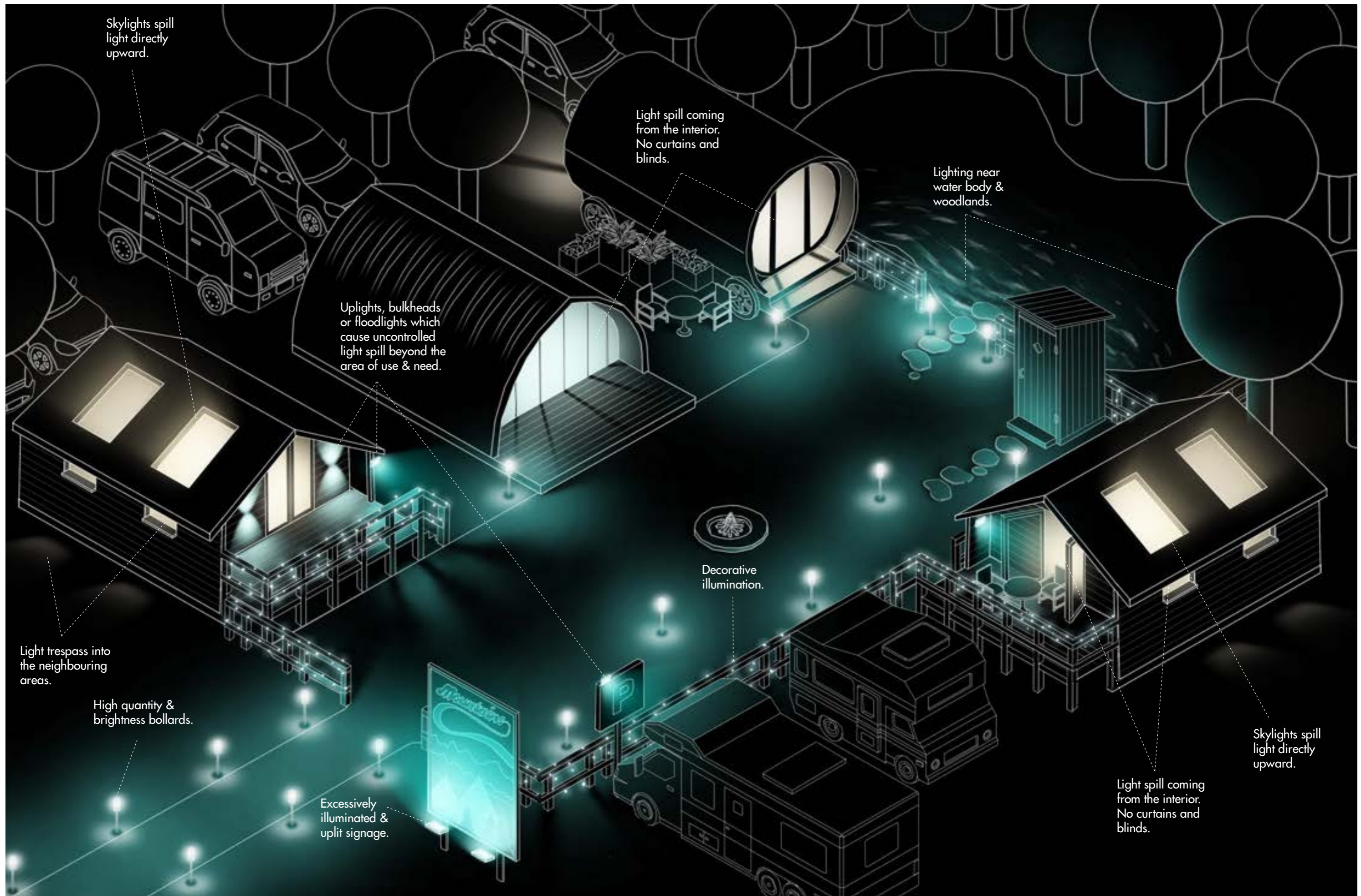

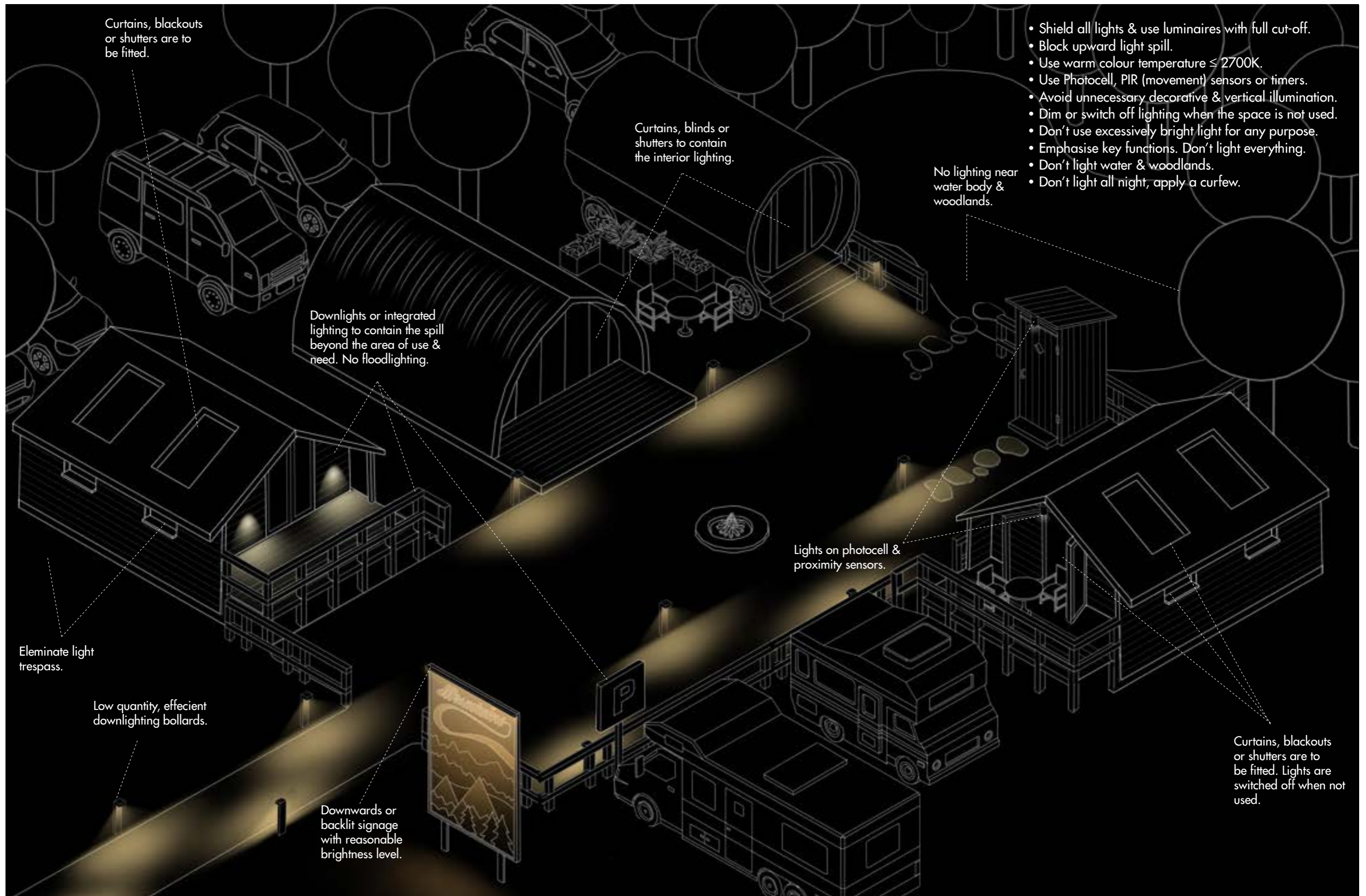

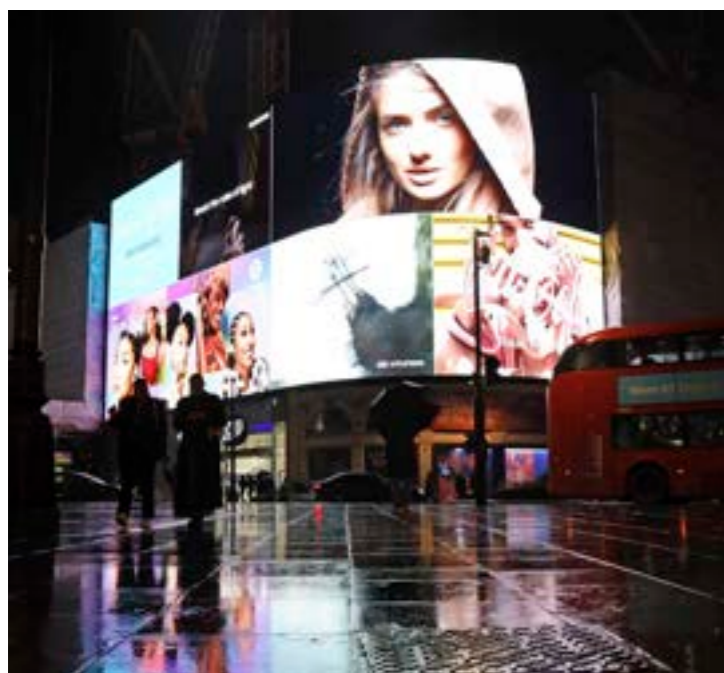

Illuminated Advertisements & Video Displays

Illuminated signs and media facades can have significant impact. Surface brightness of any lit surface should not exceed the luminance value of 100 cd/m². Higher luminance means the surface is brighter or source is glary. The surface area of any illuminated display should not exceed 18m².

Actively illuminated signs (apart from the luminous media walls) must employ downlighting methodology. Lighting must be mounted on the sign, not using free-standing or remote luminaires.



Temporary Lighting

Temporary lighting can contribute to a significant impact within a short period of time. This term refers to any festival, event, construction or mobile flood-lighting.

Specific assessments should be made to ensure that artistic installations, light festivals, temporary event lighting, music festivals & etc are carried out with an environmental ethos. Uplighting, skyscanners, lasers and any light above 2700K CCT must be avoided.

If the temporary lighting is seen to be used more than 28 days or with consistent regularity during a year period, then planning permission should be sought.



Innovative technologies

There are several innovative technologies such as smart path surfaces, reflective pavement/curb/step strips, motion triggered lighting systems and etc. Many of these rely on passive or low illumination making them a valuable asset for dark skies. Applicants are encouraged to explore the potential of such innovative solutions available.



Security lighting & CCTV systems

There is no strong evidence which suggests that lighting deters crime. In order to reduce wasting of the light with the sole purpose of aiding cameras, low light, infrared and night vision CCTV or wireless camera systems must be taken into consideration.



Lux and lumens are properties of light that are useful to assess the appropriateness of lighting installations.

Lumens (Luminous Flux): The total light radiated by a lamp. 500 lumens is sufficient for most domestic needs.

Candela (Luminous Intensity): The intensity of light in a given direction.

Lux (Illuminance) Lumens per m2: The illumination on a surface. A higher value lux means the illumination is brighter.

Surface Brightness (Luminance) Candela per m2: The intensity of light emitted from a surface per unit area in a given direction.

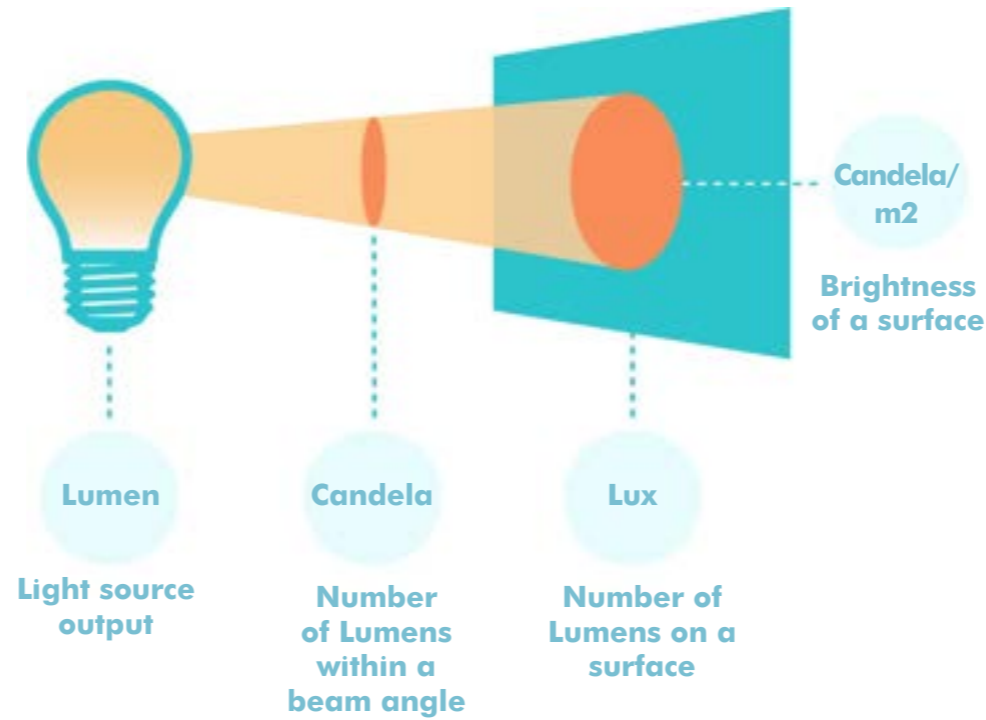

Luminance

This measure is used for describing the brightness of vertical surfaces & light sources including media walls. A higher luminance means the surface is brighter or source is glary. Surface brightness of any lit layer should not exceed 100 cd/m².

Light Distribution is a very important feature of a dark sky friendly luminaire. Light should only be projected downwards and luminaire's beam **should not exceed 80°**. Narrower the beam, lesser the glare. If backspill is not acceptable, the beam should be narrow & asymmetric. Zero ULOR (Upward Light Output Ratio) and Full Cut-Off means that the luminaire does not emit any light above the horizon line.

Colour Temperature is often referred to as the CCT of the source. Cool white (or the blue-rich) lighting is the most harmful to wildlife and humans. There is a substantial growing body of evidence that shows that the colour temperature, CCT of the lights can be particularly disruptive to circadian rhythms, sleep patterns and the production of melatonin. No lighting should be installed with a CCT in excess of 2,700K, and warmer colours of <2,200 - 2,400K are proven to be less harmful to wildlife. The blue-white spectral content below 490nm must be minimal (<5%).

Colour Rendering Index (CRI or Ra) is a quantitative measure of the ability of a light source to reveal the actual colours of an object or space. Broad spectrum should be avoided to eliminate the spill of harmful wavelengths, particularly in the Ultra-Violet which affects wildlife. Exterior lighting CRI **should not exceed Ra90**.

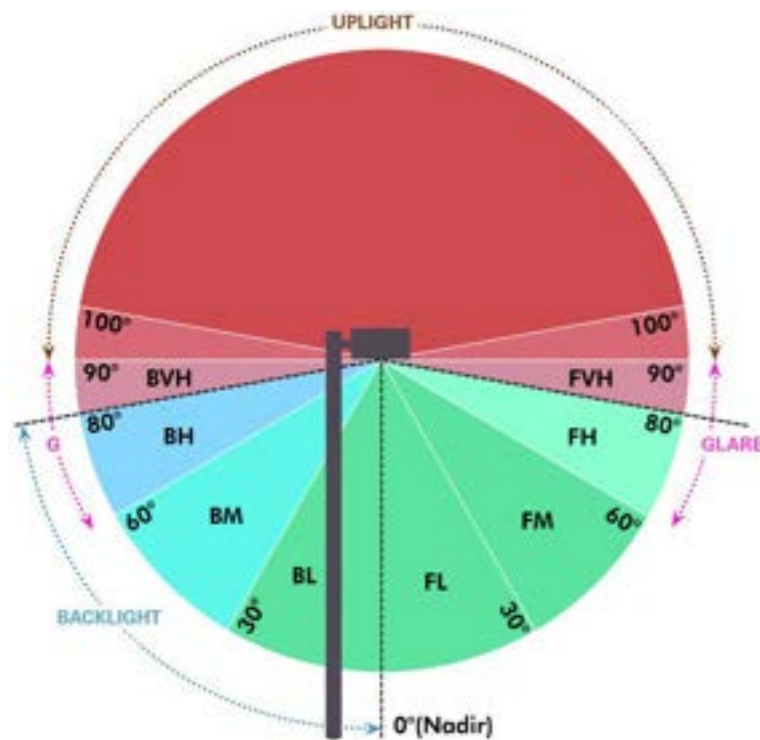

BUG Rating - Bead Distribution Diagram

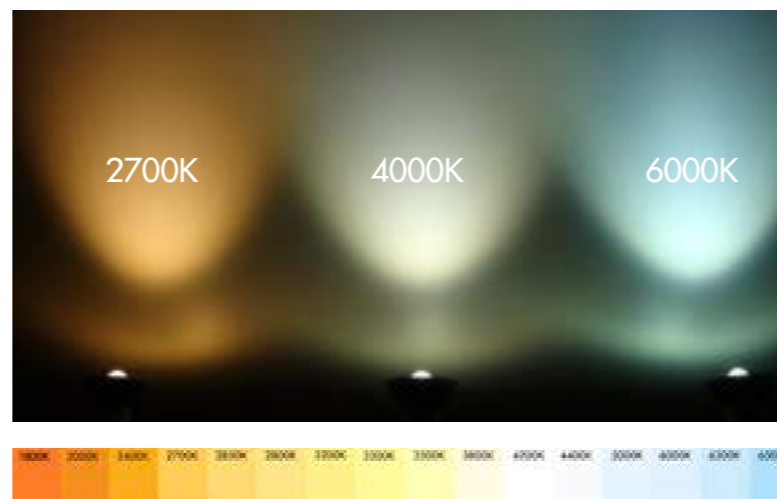

CCT range

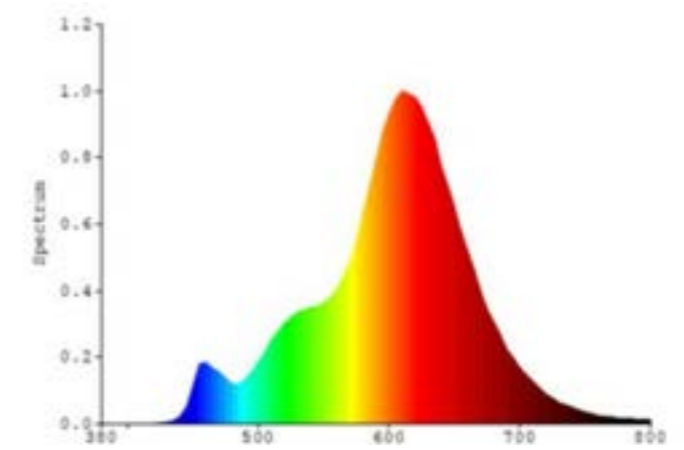

Example of a 2200K Ra80 CRI Spectrum

Light pollution - GOV.UK (www.gov.uk)

Refer to pages 8-12 within: New Resource: [Towards a Dark Sky Standard](#) | Institution of Lighting Professionals (theilp.org.uk)

- ILP GN 01/20: Guidance note for the Reduction of Obtrusive Light – updated: [ILP Guidance Note 1: the reduction of obtrusive light has been updated](#) | Institution of Lighting Professionals (theilp.org.uk)
- ILP PLG05 The brightness of illuminated Advertisements - updated: [PLG05 THE BRIGHTNESS OF ILLUMINATED ADVERTISEMENTS](#) | Institution of Lighting Professionals (theilp.org.uk);
- Historic England: External Lighting of Historic Buildings: [External Lighting of Historic Buildings](#) | Historic England
- Information from the Bat Conservation Trust on artificial lighting, and Eurobats guidelines for consideration of bats in lighting projects: [Artificial Lighting Guidance - Buildings, planning and development - Bat Conservation Trust](#) (bats.org.uk)
- British Standards Publication, Design of Road Lighting: [5489-1-2020](#)
- CIBSE/SLL TM66 A Circular Economy Assessment Method 2023: [TM66 - Creating a circular economy in the lighting industry now available](#) | CIBSE

This list is not exhaustive and are not to be applied as a 'one-size-fits-all' solution. Each provides general guidance that does not replace the requirement to undertake a specific professional site assessment to inform each individual lighting design.

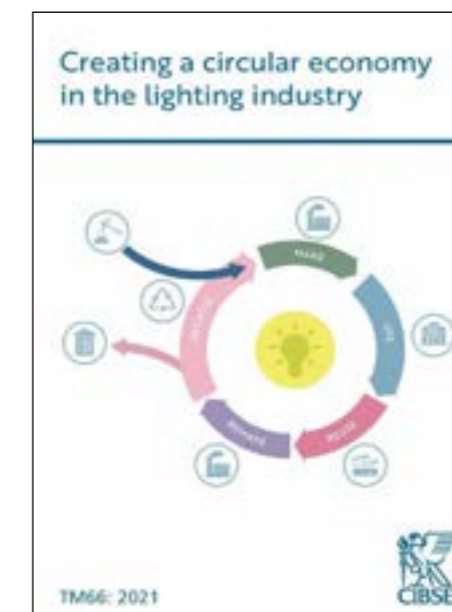
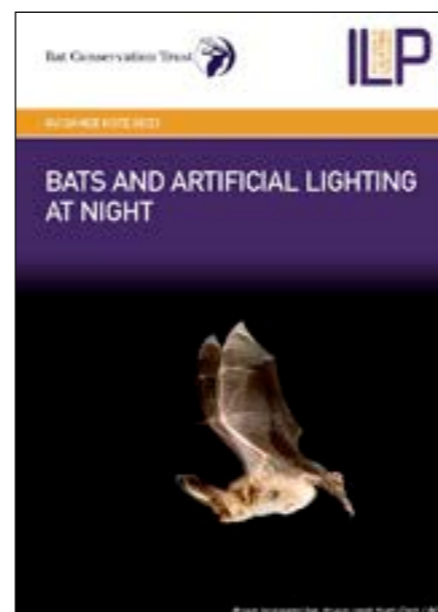
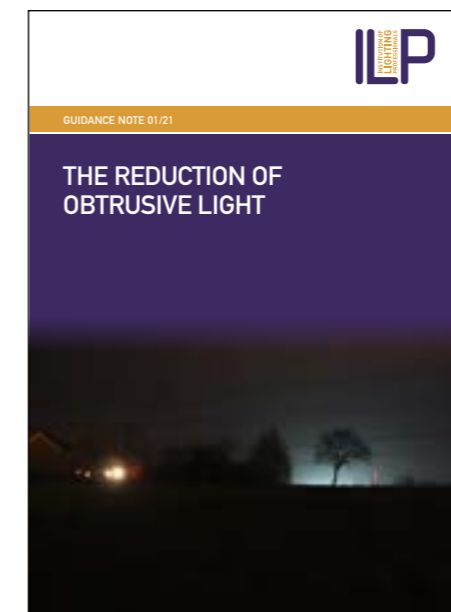
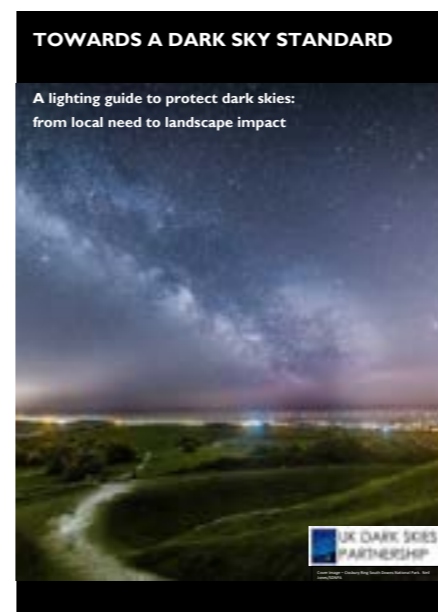

Lighting baseline assessments, ecological and visual impact assessments, lighting and design & access statements need to take into account a wide range of potential impacts from light pollution given Cumbria's special attributes and policy goals. Local Plan policies cover all these factors, seeking to protect natural resources and foster positive outcomes from developments.

SOCIAL:

(1) **Good lighting is one of several factors contributing to people's feeling and perception of safety.**

[Perceptions of Night-Time Safety Women and Girls - Arup](#)

(2) **'Brighter isn't always safer': Perceptions and feelings of safety can be harmed through over illumination, lights glaring into people's eyes or causing shadowing.**

[Using street lighting to support pedestrian safety at night | Faculty of Social Sciences | The University of Sheffield](#)

(3) **Lighting by itself doesn't necessarily reduce crime rates and may increase certain types of crime.**

[Street lighting may enable rather than hinder street crime | myScience / news / news 2022](#)
[The benefits and limitations of external lighting | The Crime Prevention Website](#)
[What is the effect of reduced street lighting on crime and road traffic injuries at night? A mixed-methods study \(nih.ac.uk\)](#)

(4) **Light intrusion can harm people's sleep and hormone melatonin production, which is vital for our immune system and health.**

[Artificial Night Light & Use of Hypnotic Medications in Older Adults: A Population-Based Cohort Study Light Aware](#)
[Circadian rhythm disruption & mental health PubMed](#)
[Lack of Sleep Costing UK Economy Up to £40 Billion a Year | RAND](#)
[Linking more diseases to Light at Night | Medscape](#)
[Night light exposure link with Alzheimer's | FiN](#)

(5) **Sensitive groups experience glare more often and are disproportionately affected by intense lighting or "photophobia" i.e. abnormal light intolerance.**

[Frontiers | High Prevalence of Self-Reported Photophobia in Adult ADHD \(frontiersin.org\)](#)

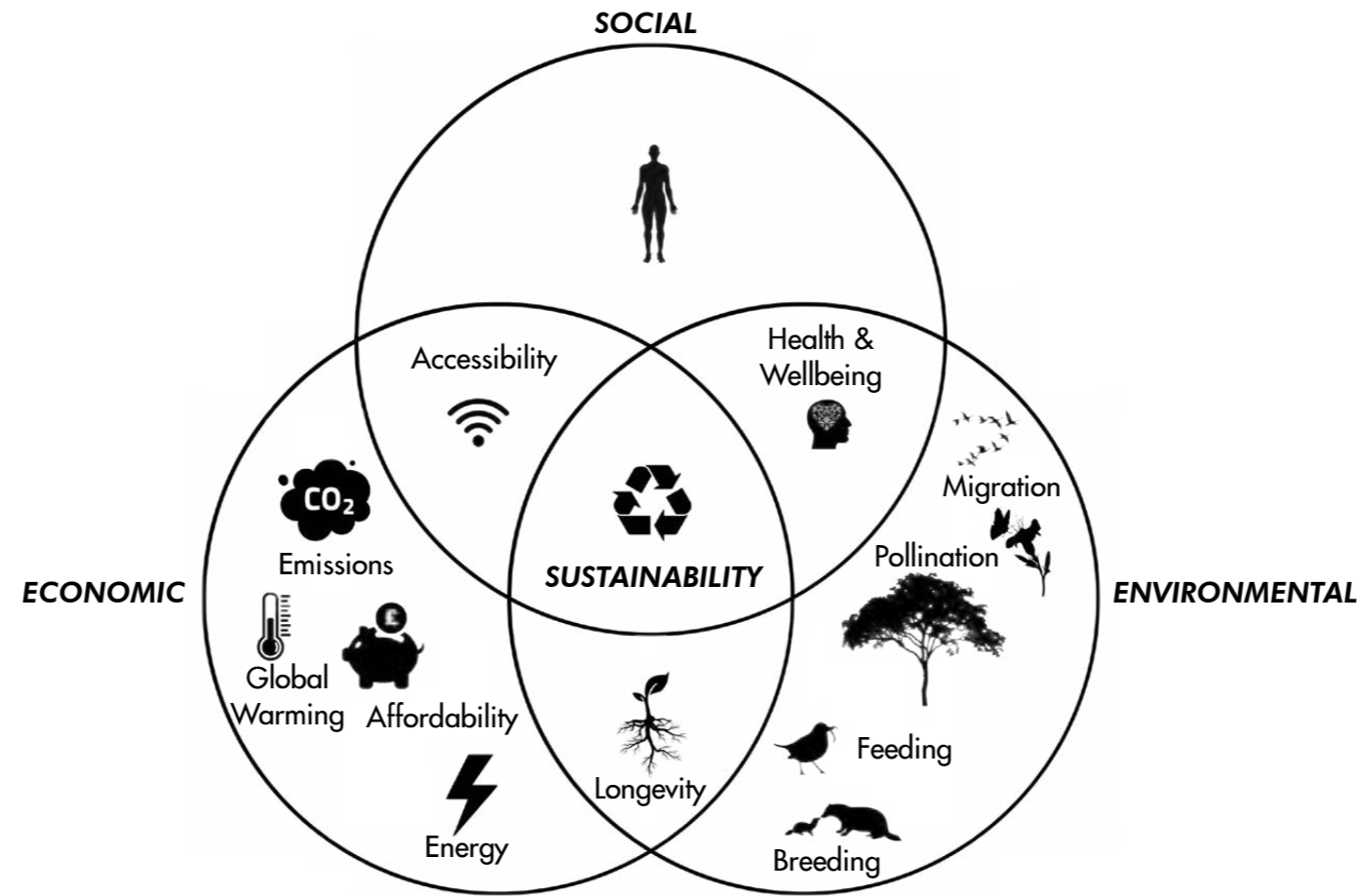

ECONOMIC:

(6) **Light pollution is wasted light, adding to energy costs, carbon emissions and affecting the business profits and households budgets.**

[Cost of living crisis: councils face winter of 'difficult decisions' as spiralling inflation adds £1.5bn to costs - County Councils Network](#)
[Zero Carbon Cumbria Programme - CAFS](#)

(7) **Inefficient poor lighting imposes higher capital and maintenance costs.**

(8) **Astro-Tourism adding value to the night-time economy and leisure sector.**

[Cumbria Dark Skies Festival - Visit Lake District](#)
[Importance of Dark Skies to Tourism | Friends of the Lake District](#)

NATURAL ENVIRONMENT & BIODIVERSITY:

(9) **Species loss and habitat damage needs reversing. 30% of Vertebrates and around 60% of Invertebrates are active during darkness. A growing body of evidence shows that insensitive lighting harms wildlife in numerous ways, for example:**

(10) **Restricting Pollination - 87% of plants need animal pollination, mostly insects and moths.**

[Artificial light at night as a new threat to pollination | Nature](#)
[Ecological benefits of part-night lighting revealed: Night-time pollinators benefit from street lights being switched off in the middle of the night -- ScienceDaily](#)
[The Impact of Artificial Light on Invertebrates | Buglife](#)

(11) **Reducing Breeding Success – affecting many species, including Insects, Amphibians and Birds.**

[Street lighting has detrimental impacts on local insect populations | Science Advances](#)
[Artificial light at night disturbs the activity and energy allocation of the common toad during the breeding period | Conservation Physiology | Oxford Academic \(oup.com\)](#)
[Artificial night lighting causes birds to sing earlier | Max-Planck-Gesellschaft \(mpg.de\)](#)

(12) **Migration and Collisions of Birds – orientation towards intense lighting and crash landing on the ground or into structure/ buildings.**

[The argument for switching off lights at night - BBC Future](#)
[Light Pollution Poses Threat to Migrating Birds - International Dark-Sky Association \(darksky.org\)](#)
[Factors influencing Manx Shearwater grounding on the west coast of Scotland - Syposz - 2018 - Ibis - Wiley Online Library](#)

(13) **Restricting Feeding Ability – larger Bat species, such as Natterers and Brown Long-Eared, are highly sensitive to artificial lighting mimicking day light.**

[Light Pollution and Bats | Friends of the Lake District](#)
[Guidance Note 8 Bats and artificial lighting | Institution of Lighting Professionals \(theilp.org.uk\)](#)
[Effects of dimming light-emitting diode street lights on light-opportunistic and light-averse bats in suburban habitats | Royal Society Open Science \(royalsocietypublishing.org\)](#)

(14) **Aquatic species & habitats – the action of artificial light penetrating into water bodies impacts aquatic insects, migratory fish and coastal habitats.**

[Some Like it Dark: Light Pollution and Salmon Survival - FISHBIO | Fisheries Consultants](#)
[Aquatic insects are sensitive to light pollution - IGB](#)
[Artificial Lighting at Night in Estuaries—Implications from Individuals to Ecosystems | SpringerLink](#)

(15) **Tranquillity of landscape & skyscape – light pollution affects every scale of space from local amenity to sky glow from major light sources.**

Nature connectedness in tranquil environments supports people's health and well-being.
[Saving tranquil places - report.pdf \(cpre.org.uk\)](#)
[Increasing light pollution is drowning out the stars | Natural History Museum \(nhm.ac.uk\)](#)
[Engagement with natural beauty moderates the positive relation between connectedness with nature and psychological well-being - ScienceDirect](#)
[Connection to Nature | Why Connecting with Nature is Important - RSPB](#)

These example conditions are all derived from real cases within Cumbria, or in a small number of cases, from elsewhere in England. They are just to be used as a guide and will need adapting to individual circumstances and contexts.

An example informative is also provided.

*** Policy X refers to the authority's own relevant policy.**

When lighting details are all provided in application:

The development hereby permitted shall not be carried out otherwise than in conformity with the following submitted plans and details: - (refer to drawing/plan/document reference number e.g. Drawing A (External lighting))

Reason: For the avoidance of doubt and in order to minimise the effects of external lighting upon the tranquillity and intrinsically dark landscape of the open countryside in accordance with Policies XXX.

External lighting of the site shall be in accordance with the approved External/internal lighting plan (may wish to use specific reference) only and maintained in accordance with these details. Details of any additional external lighting shall be submitted to, and agreed in writing by, the Local Planning Authority prior to installation.

Reason: For the avoidance of doubt and to safeguard the amenities of the area in accordance with the provisions of Policy X.

When lighting details are not provided in application:

No external lighting shall be installed on the site other than in accordance with details which have first been submitted to, and approved in writing by, the Local Planning Authority prior to installation. Such lighting shall be maintained in accordance with the approved details thereafter. The approved scheme shall be installed and fully assessed by a suitably qualified individual when operational. The scheme shall include a layout plan with beam orientation and a schedule of light equipment proposed. Thereafter, the lights must be permanently maintained and operated in accordance with the approved details.

Reason: For the avoidance of doubt and to safeguard the amenities of the area in accordance with the provisions of Policy X and the National Planning Policy Framework.

Permitted development for Lighting removed by condition:

Notwithstanding the provisions of the Town and Country Planning (General Permitted Development) Order (or any order revoking and re-enacting those Orders with or without modification), no additional external lighting shall be attached or installed at the application site without the prior written agreement of the Local Planning Authority. Any approved lighting shall then be installed and operated in accordance with an agreed lighting scheme.

Reason: To ensure the protection of dark skies, landscape character, biodiversity and amenity in accordance with policy X.

No external lighting shall be installed without application for, and grant of planning permission by, the Local Planning Authority.

Reason: To safeguard the amenities of the landscape and to minimise the risk to disturbance to protected species.

Larger-scaled Developments:

No development shall take place, including any works of demolition, until a Construction Management Plan (CMP) has been submitted to, and approved in writing by, the Local Planning Authority. Thereafter the approved CMP shall be implemented and adhered to throughout the entire construction period. The CMP shall provide details as appropriate but not necessarily be restricted to the following matters. iv) **Details of any floodlighting, including location, height, type and direction of light sources and intensity of illumination.....**

Prior to the installation of any external lighting, including street lighting, a lighting assessment and plan, carried by a suitably qualified lighting engineer, shall be submitted to and approved in writing by the Local Planning Authority. The lighting plan shall include the following detail: i) Baseline conditions, including details of any existing lighting, or any nearby lighting ii) The need for the lighting; iii) What standards are to be used; iv) The position of all proposed lighting; v) The installation details of all proposed lighting (angle, tilt, height); vi) Technical specifications of the lighting including lumen output and colour temperature; vii)

The Glare Rating and colour temperature of all new street lighting, with best endeavours to achieve a Glare Limiting Index of G6 and a light source colour temperature of 2,700K or less. viii) Night time curfews with 50% dimming between 9pm and 6am with best endeavours to achieve a part night time switch off between 11pm and 5am.

Reason: To ensure that the any external lighting protects dark skies and the general amenity of the area, in accordance with policy X of the Local Plan.

No external lighting shall be installed until a lighting scheme, including details of the design, size, luminance level and shielding arrangements have been submitted to and approved in writing by the Local Planning Authority. The lighting shall be installed in accordance with the approved scheme and retained thereafter.

Reason: These details are required to be approved before the commencement of development to safeguard and enhance the character of the area in accordance with Policy X.

Post-Development Compliance Monitoring:

Within THREE months following completion, a night-time assessment of the lighting installed as part of the development hereby permitted will be undertaken and submitted for inspection and approval by an appropriate Officer of the Local Planning Authority.

Reason: To ensure that the lighting installed matches the approved lighting plan and/or lighting design specifics.

Example Informative:

The applicant should refer to the Cumbria Good Lighting Technical Advice Note for guidance when designing any lighting scheme or providing any other lighting information required by the above condition(s).

Advertisement Consent:

The sign permitted by this consent shall only be illuminated during the opening hours of the premises to which it relates.

Reason: To ensure that the character of the area is not adversely affected in accordance with Policy X of the local plan.

The intensity of the illumination of the signs permitted by this consent shall be no greater than 100cd/m² for the LED backlighting and the digital display screens.

Reason: To ensure that the character of the area is not adversely affected in accordance with Policy X of the local plan.

Smaller/ specific /proposals for lighting only

The lighting columns hereby approved shall be dimmed to 50% of full output between 00:00 and 05:00 hours.

Reason: In the interests of the environmental amenities of the area.

The external lighting of the synthetic sports pitches shall be in accordance with the details in the submitted Feasibility Stage Report by Surfacing Standards Limited dated XXX including its purpose, number, position, type, size, specification and luminance of the lighting and the means of directing or use of cowling/shielding to prevent upward light spill. The lighting and any replacement of the external lighting shall accord with the approved details and be retained as such thereafter.

Reason: In the interests of visual & neighbour amenity and protection of Dark Skies in accordance with policy X of the local plan.

The proposed lighting shall be turned off by midnight or if there is a function taking place by 01:30 hours or 30 minutes after the end of the function (whichever is the earlier).

Reason: To reduce the impact of the lighting at night, in accordance with Policy X of the local plan.

The intensity of the illuminated sign(s) permitted by this consent shall be no greater than 100cd/m².

Reason: To ensure that the character of the area is not adversely affected in accordance with Policy X of the local plan.

Floodlighting provided for use on the training pitch shall not be used other than between 10.00 and 21.30 hours

Reason: To minimise the visual impact of light emitted from the site on neighbouring light sensitive locations, and in the interests of visual amenity.

Glazing:

Prior to the insertion of any new window, door or rooflight into the dwellinghouses the subject of this permission details of the following shall be submitted to the Local Planning Authority for approval:

1) design of the windows drawn to a scale of no less than 1:20 and showing reveal depths and the dimensions of glazing units.

2) the finish of all windows, rooflights and doors
Thereafter the works shall be carried out in accordance with the approved details.

Reason: To safeguard the character and appearance of this building in accordance with Policy CS11 and CS27 of Lake District National Park Core Strategy (Local Plan Part One).

Lighting - Reasons for refusal:

These reasons have all been given in refusal of applications in Cumbria since 2018:

- Impact on character and quality of the local landscape and of the wider countryside, and the need to minimise light pollution.
- Impact of light pollution from artificial light on intrinsically dark landscapes
- the lighting proposed is harmful to the distinctive landscape and character of the surrounding area, due to their number and location and by introduction of further light pollution into the open countryside
- The indicated need for the lights does not outweigh the harm that is caused
- The application is silent on the lighting requirements
- The proposals would unacceptably impact on the amenity of adjacent residents due to the additional activity, noise and disturbance, visual intrusion, overlooking and light pollution,

Lighting – Appeal decisions:

These reasons have all been given in refusal on appeal of applications in Cumbria since 2018:

“The relative absence of dwellings and settlement means that there are minimal sources of light and this helps to maintain the dark skies. Therefore, even though the amount of light produced may not be substantial, in this location even a small amount of light would affect the sense of isolation and erode the quality of the local landscape”

“I have found that all of the posts and lights are unacceptable, and that there are no planning conditions that could make this development acceptable. Therefore, there are no lesser steps that would achieve the statutory purpose behind the notice and the appeals on ground (f) must fail”

“Visually, the large area would be subject to a significant degree of change in its character. During darkness hours a significant urbanising effect would persist due to a requirement to illuminate the site to assist users”.

OVERVIEW OF LOCAL PLAN POLICIES RELEVANT FOR CUMBRIA GOOD LIGHTING TECHNICAL ADVICE NOTE

This appendix only lists policies where there are specific references to tranquillity, lighting, light pollution or dark skies. There will be other policies that may not make specific references but that are nevertheless relevant such as biodiversity and landscape policies.

Please note that local plans will be developed for the two new unitary authorities in Cumbria, replacing the local plans in the former Allerdale, Barrow, Carlisle, Copeland, Eden and South Lakeland areas, but until such time, the following local plan documents apply (position as at June 2023)'.

Lake District National Park Authority

The [current local plan](#) was adopted in May 2021 includes relevant references as follows:

Paras. 3.02.18, 3.05.04-05

Principles of Development (not a policy) p.24

Policy 05 Protecting the spectacular landscape (supported by para. 3.05.04, ref to light as a dimension of tranquillity)

This policy also requires development decisions to be informed by the [Lake District Landscape Character Assessment](#), which is an adopted Supplementary Planning Document (SPD) and includes references to tranquillity and light pollution/dark skies in relation to several of the landscape typologies descriptions of the Areas of Distractive Character.

Policy 06 Design and Development

Policy 13 Central and South East Distinctive Area makes reference to supporting lighting that is sympathetic to the historic towns and buildings of Windermere and Ambleside.

There is a brief reference to lighting impacts in the [Biodiversity SPD](#)

There are some references to lighting/light pollution in the [Windermere Gateway SPD](#)

Dark Skies are referred to in the [Lake District Partnership Plan](#) – the Management Plan for the Lake District pp.28 and 125

The [Lake District Design Code](#) makes several references to light, lighting and glazing.

Yorkshire Dales National Park Authority

Note that in some areas now in the YDNP, local plan policies from other districts (Eden and South Lakeland) still apply as the YDNP has been extended since the current local plan was adopted.

[Current Local Plan](#) adopted Dec. 2016. includes relevant references as follows:

Policy SP3, SP4 Development Quality – sections (s) and (t)

Para. 1.9, 2.20, 2.31, 5.63, 6.8, 6.27, 6.30

Policy BE3 Re-use of modern buildings

Para. 3.37

Policies T1 Camping and T2 Touring Caravan Sites

Para. 6.8

Dark Night Skies is specified as one of the Special Qualities of the National Park - "as it suffers little from light pollution, the moon, night sky and atmospheric effects can be fully appreciated".

Protecting dark night skies is listed as one of the Cultural Landscape Objectives

A new Local Plan is currently in preparation and is expected to be adopted in 2026.

[The Yorkshire Dales Landscape Character Assessment](#) is also relevant.

Allerdale

Local Plan in two parts includes relevant references as follows:

[Local Plan Part 1 adopted 2014](#) (Strategic and Development Management Policies)

Paras. 305, 309

Policies S32 Safeguarding Amenity, DM6 Equestrian and Agricultural Buildings, DM10 Improvements to the Public Realm

[Local Plan Part 2 adopted 2020](#) (Land Allocations)

Includes a requirement for several (but not all) the allocated sites with the standard wording "Development proposals will be expected to incorporate a suitable lighting scheme which will minimise light pollution, protecting the character of the immediate locality and biodiversity interests on and adjacent to the site", e.g. site SA42.

Barrow

[Local Plan adopted 2019](#) includes relevant references as follows:

Paras. 2.4.22, 3.4.9, 4.10.1-3, 10.2.3, 10.2.5, 10.5.9 (penultimate bullet point), 11.2.13, 12.1.29, Policies DS2 Sustainable Development Criteria, DS7 Development on Strategic Routes, C7 Light Pollution, EC3 Managing Development of Employment Land, GI5 Green Routes, HC5 Crime Prevention, HC8 New Outdoor Sports Facilities, HC9 Multi-Use Games Areas, HC11 Golf Courses, N1: Protecting and Enhancing Landscape Character

[Biodiversity and Development SPD \(2018\)](#) – several references to lighting/light pollution. Light is mentioned as a form of pollution in the glossary.

Carlisle

[Local Plan adopted 2016](#)

Paras. 3.86, 4.59, 8.25, 10.1, 10.3

Policies CM4 Planning Out Crime, CM5 Environmental and Amenity Protection, GI1 Landscapes,

[St Cuthbert's Garden Village Strategic Design SPD \(2021\)](#) includes minor references e.g pp. 42 and 43 final sentence on each page, p.45

Copeland

[Copeland Local Plan 2021-2039](#)

Paras. 6.4.8, 15.5.2, 15.7.1

Policy DS4: Design and Development Standards criterion m "use appropriate levels and types of external lighting that does not create light pollution and helps maintain dark skies in line with up-to-date good lighting guidance".

Eden District Council

[Eden Local Plan 2018](#)

Paras. 3.8.2, 3.8.4, 3.15.3, 3.15.6, 4.6.6, 4.19.1 Policy ENV2- Protection and Enhancement of Landscapes and Trees, ENV9- Other Forms of Pollution, EC4 - Tourism Accommodation and Facilities.

South Lakeland District Council

Local Plan in multiple parts.

[Core Strategy \(2010\)](#) – nothing about dark skies or light pollution. Landscape policy is main hook.

[Land Allocations \(2013\)](#) – nothing about dark skies or light pollution.

[Development Management Policies \(2019\)](#)

Paras. 2.1.1, 2.7.1, 2.7.4,

Policies DM2 Achieving Sustainable High Quality Design (section 10), DM7 Addressing Pollution, Contamination Impact, and Water Quality, DM19 Equestrian-related development.

Arnside & Silverdale National Landscape

There is a dedicated Development Plan Document (DPD) for Arnside & Silverdale National Landscape (the [AONB DPD](#)) – adopted 2019. The Arnside & Silverdale NL straddles the Cumbria - Lancashire boundary. About a third is in Cumbria. The AONB DPD covers the whole of the National Landscape. It includes relevant references as follows:

Paras. 1.2.1, 1.2.4(II), 3.1.29-30, 4.2.5, 4.6.8-9, 4.7.2, 4.9.4

Policies AS02 Landscape, AS08 Design, AS13 Energy and Communications

Neighbourhood Plans

There are a small number of adopted Neighbourhood Plans in the County. There may be minor references to light pollution in some of these.

[The Neighbourhood Plan for Allithwaite and Cartmel](#) includes a dedicated policy on dark skies

[Cumbria Landscape Character Guidance](#) - applies outside of the National Parks

[Cumbria County Council Development Design Guide](#) – applies to the whole County

National Planning Policy & Guidance:

<https://www.gov.uk/guidance/light-pollution>

Baseline

The SQM readings should be taken from various points in and around the site to outline the exact condition of the sky quality.

These SQM readings are taken on several clear nights (moonless & non-cloudy weather) to ensure consistency. Then the average value is taken into consideration to outline the condition on a given point.



Sky Quality Meter Example



Presteigne Sky Quality 25th February 2019, 20.00 - 22.00 hours approx.				Sky Quality Meter Reading (magnitude/arcsec ²) (MPSAS(B) reading)										Average	NELM
Latitude	Longitude	Description	Address	Reading 1	Reading 2	Reading 3	Reading 4	Reading 5	Reading 6	Reading 7	Reading 8	Reading 9	Reading 10		
52.27677	-3.0149331	Point B	Knighton Road junction, Presteigne	20.35	20.15	20.20	20.20	20.07	20.23	20.41	20.25	20.23	20.18	20.23	5.65
52.275003	-3.009861	Point C	Junction of Joe Deakins Road & Warden Road, Presteigne	18.49	18.86	18.57	18.56	18.55	18.48	18.66	18.40	18.48	18.41	18.55	4.42
52.271726	-3.0067836	Point D	Recycling Centre Station Road, Presteigne	19.22	19.78	20.12	20.09	19.93	20.09	20.10	20.08	20.13	19.98	19.95	5.46
52.269009	-3.002308	Point E	Junction of Joe Deakins Road & Broadaxe (Leisure Centre), Pre	18.93	18.99	18.85	18.87	19.03	19.04	19.02	18.93	18.90	18.86	18.94	4.73
52.266718	-2.9987613	Point F	Junction of Joe Deakins Road & B4362, Presteigne	20.87	20.85	20.83	20.83	20.82	20.83	20.83	20.83	20.84	20.84	20.84	6.02
52.264886	-2.9963649	Point G	Kington Roundabout, B4355, Presteigne	19.12	19.08	19.11	19.04	19.08	19.08	19.10	19.30	19.06	19.15	19.11	4.86
52.269174	-3.0067514	Point H	Far end of Broadaxe Business Park, Presteigne	19.99	19.83	19.93	20.10	20.07	20.13	20.17	20.08	20.08	19.93	20.03	5.51
52.27052	-3.0085378	Point I	Far end of Presteigne Industrial Estate, Presteigne	18.24	18.77	19.00	18.76	18.69	18.65	19.00	18.93	19.07	19.06	18.82	4.63
52.271183	-3.0119067	Point K	Junction of Green End & Caenbrook Meadow, Presteigne	20.41	20.26	20.24	20.30	20.30	20.40	20.38	20.39	20.40	20.39	20.35	5.72
52.275411	-3.0153102	Point L	52 Warden Close, Presteigne	19.26	19.31	18.96	19.31	19.34	19.51	19.00	18.65	18.66	18.90	19.09	4.84
52.275311	-3.0089117	Point M	Scottleton Street (near Royal Oak pub), Presteigne	17.71	17.80	17.82	17.81	17.81	17.79	17.74	17.78	17.65	17.72	17.76	3.77
52.273468	-3.0064628	Point N	Old Post Office, 1 High Street, Presteigne	17.44	17.52	17.50	17.44	17.61	17.64	17.62	17.67	17.62	17.60	17.57	3.60
52.275426	-3.0031745	Point O	Lugg Bridge, Broad Street, Presteigne	20.93	20.93	20.85	20.85	20.85	20.84	20.85	20.85	20.86	20.86	20.87	6.04
52.271615	-3.0030598	Point P	Junction of Lugg View & Hereford Street, Presteigne	16.59	16.73	16.30	16.18	16.61	16.56	16.48	16.52	16.51	16.45	16.49	2.64
52.270604	-3.0012421	Point Q	Junction of Greenfield Road & Orchard Close, Presteigne	18.72	18.71	18.69	18.68	18.76	18.66	18.70	18.71	18.65	18.63	18.69	4.53
52.26924	-2.9959751	Point R	Leominster roundabout, B4362, Presteigne	18.54	19.20	19.15	18.74	19.25	19.01	19.17	19.01	18.84	18.25	18.92	4.71

SQM readings by Leigh Harling-Bowen for Presteigne Dark Sky Project (before the lighting refurbishment)

Baseline

If the site is already illuminated, typical illuminance (Lux) and colour temperature (CCT) readings of the horizontal plane (and vertical plane if there are structures, trees or particular sensitivities on site) must be submitted in order to identify the baseline conditions. These values can be mapped out such as the indicative diagram shown on the right.

- A calibrated quality light-meter (luxmeter) must be used (not an app on a phone).
- Vertical & horizontal light measurements should be taken typically at ground and at 1.5m high at all points which are deemed sensitive (residential facades, roosts, heritage areas, SSSI & etc).
- The baseline study can be helped by photographs.
- If possible, it's encouraged that the spectral readings are taken. This allows the blue content level of the light spectrum, colour-rendering index (CRI) and flicker rate to be identified which can later be used for comparing the spectrum and flicker improvement rate as per the example below.

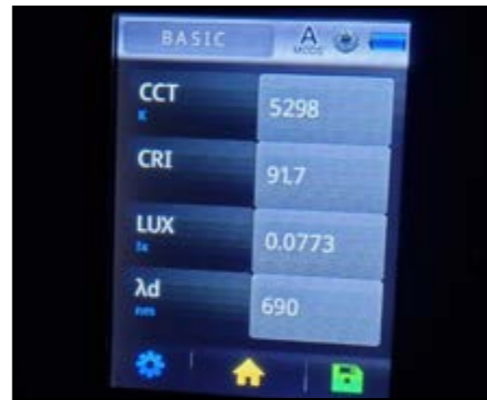

Lux-meter examples

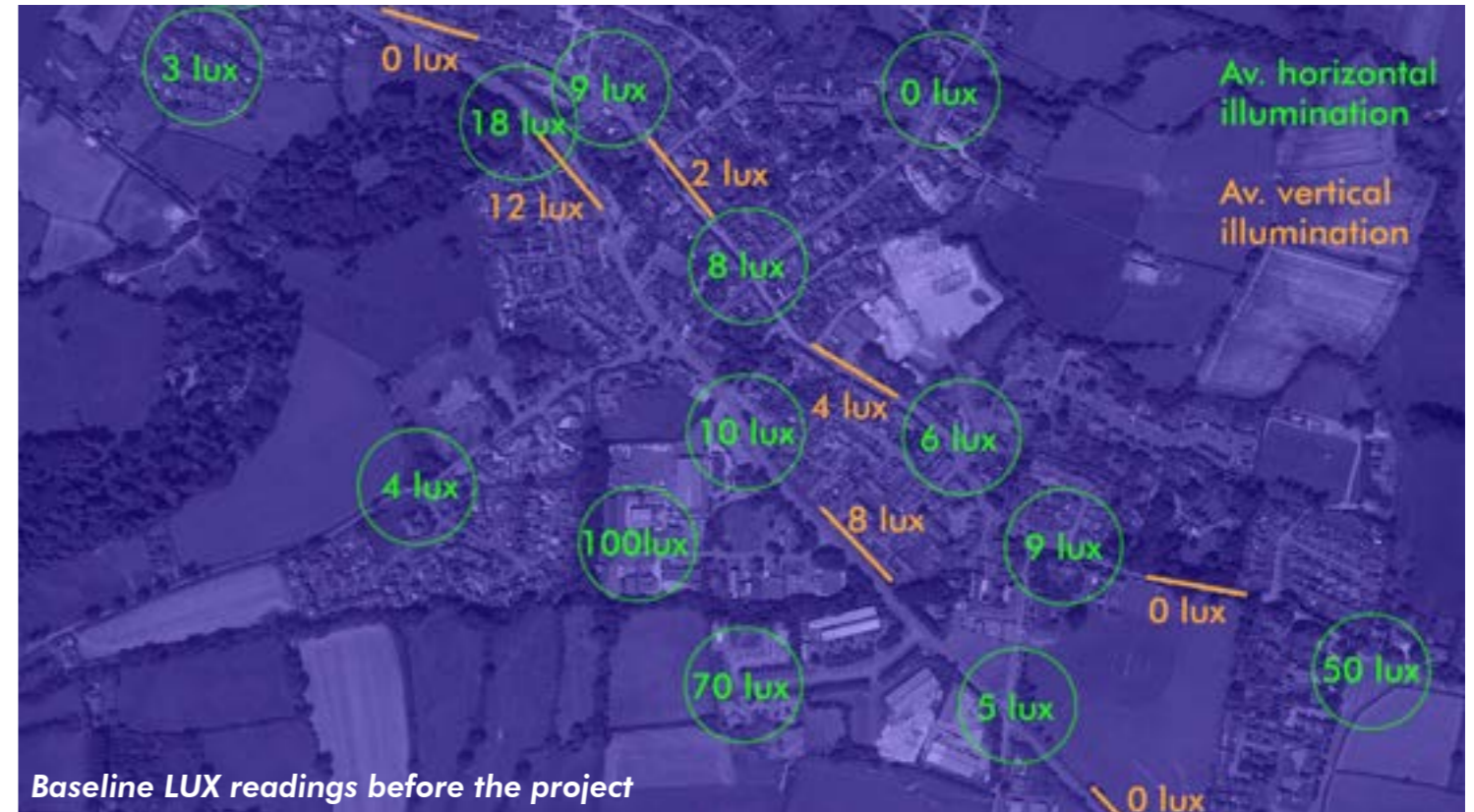

Baseline LUX readings before the project

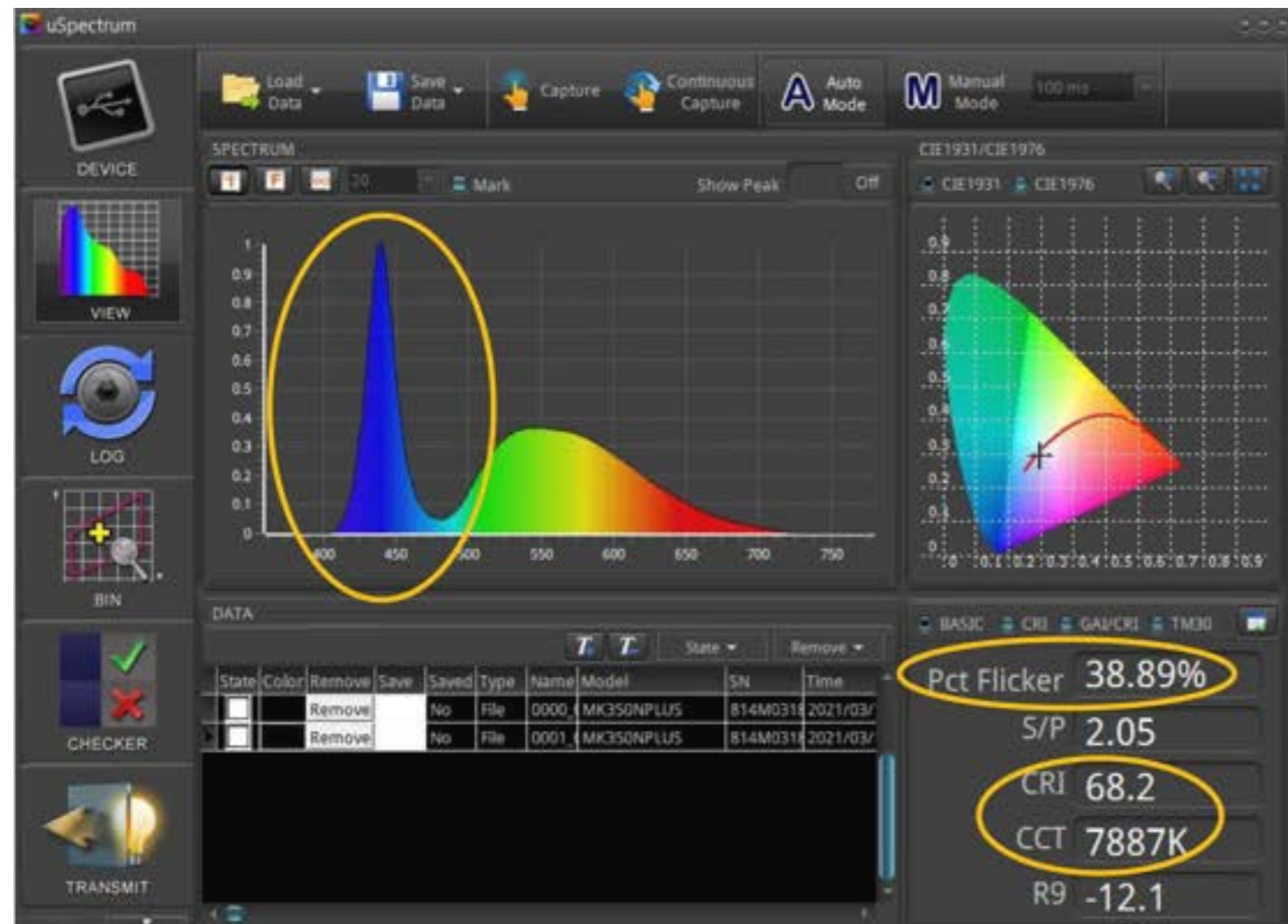

Prestegne Dark Sky Project spectral readings showing the improvement rate before & after the street lighting refurbishment. Courtesy of Brian Healy.

Example

Illustrative visuals are not essential but helpful in terms of conveying the design to the viewer quickly. Any visuals or diagrams which can help communicate the project as clearly as possible are welcome to be included in the application.



Indicative visuals of Cloughjordan Ecovillage Project by Dark Source

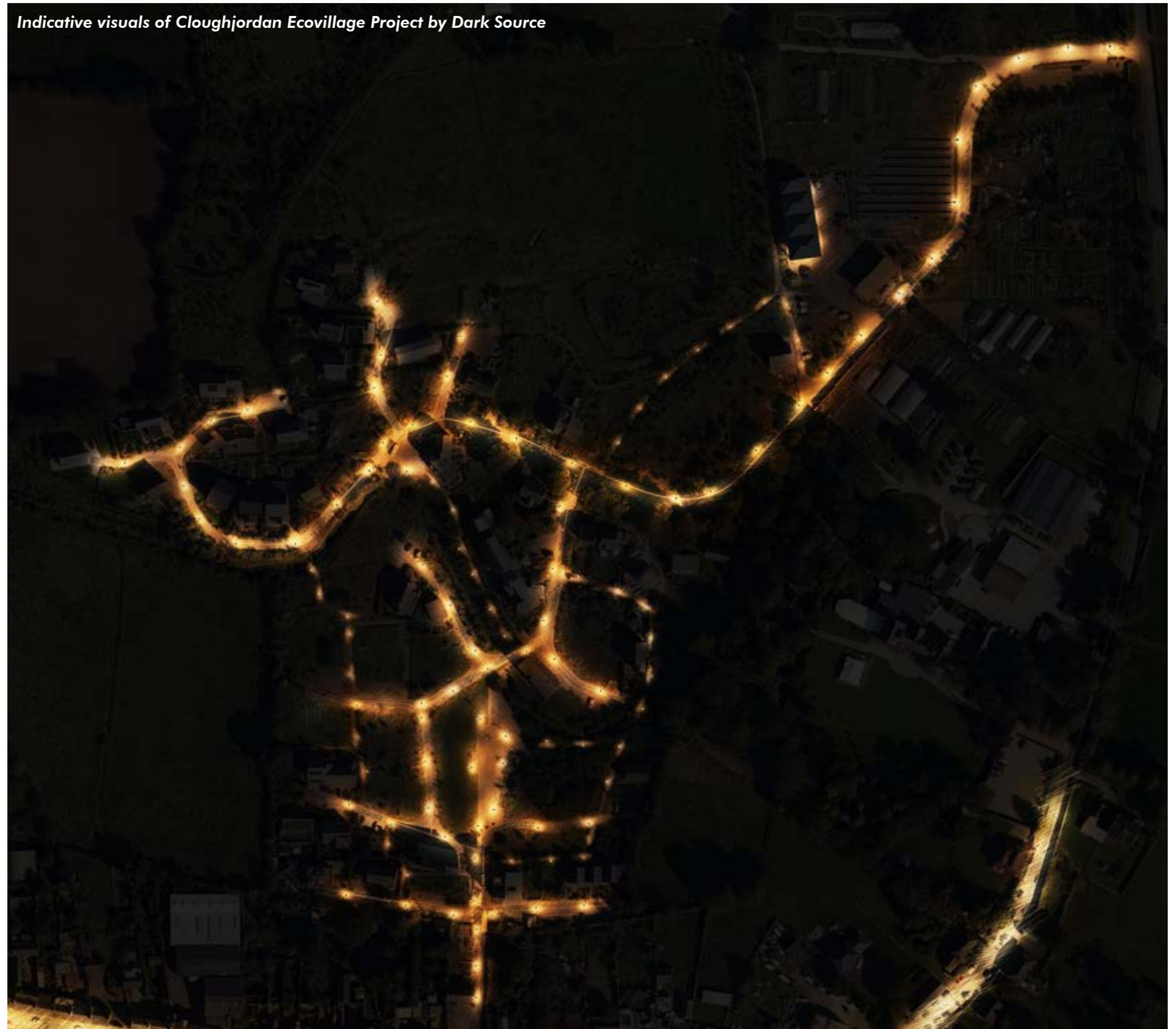

Example

A legible & scaled lighting plan drawing is required to show the location of every single external luminaire type and light source whether they form a part of the new proposal or if they are existing luminaires which the proposal wishes to retain. The aim is to convey the information as comprehensive and complete as possible.

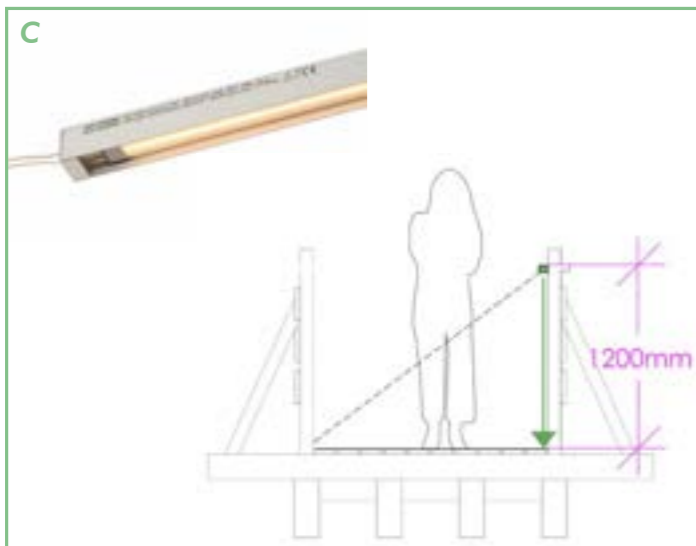
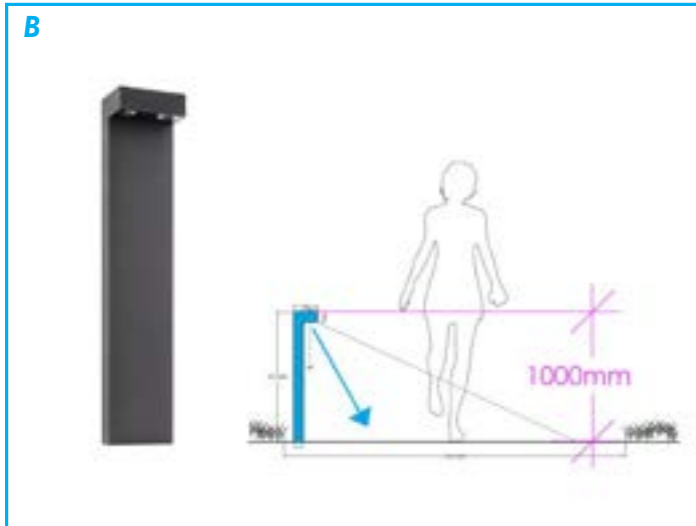

**Very large areas must be broken into smaller plan drawings if the scale is not legible.*

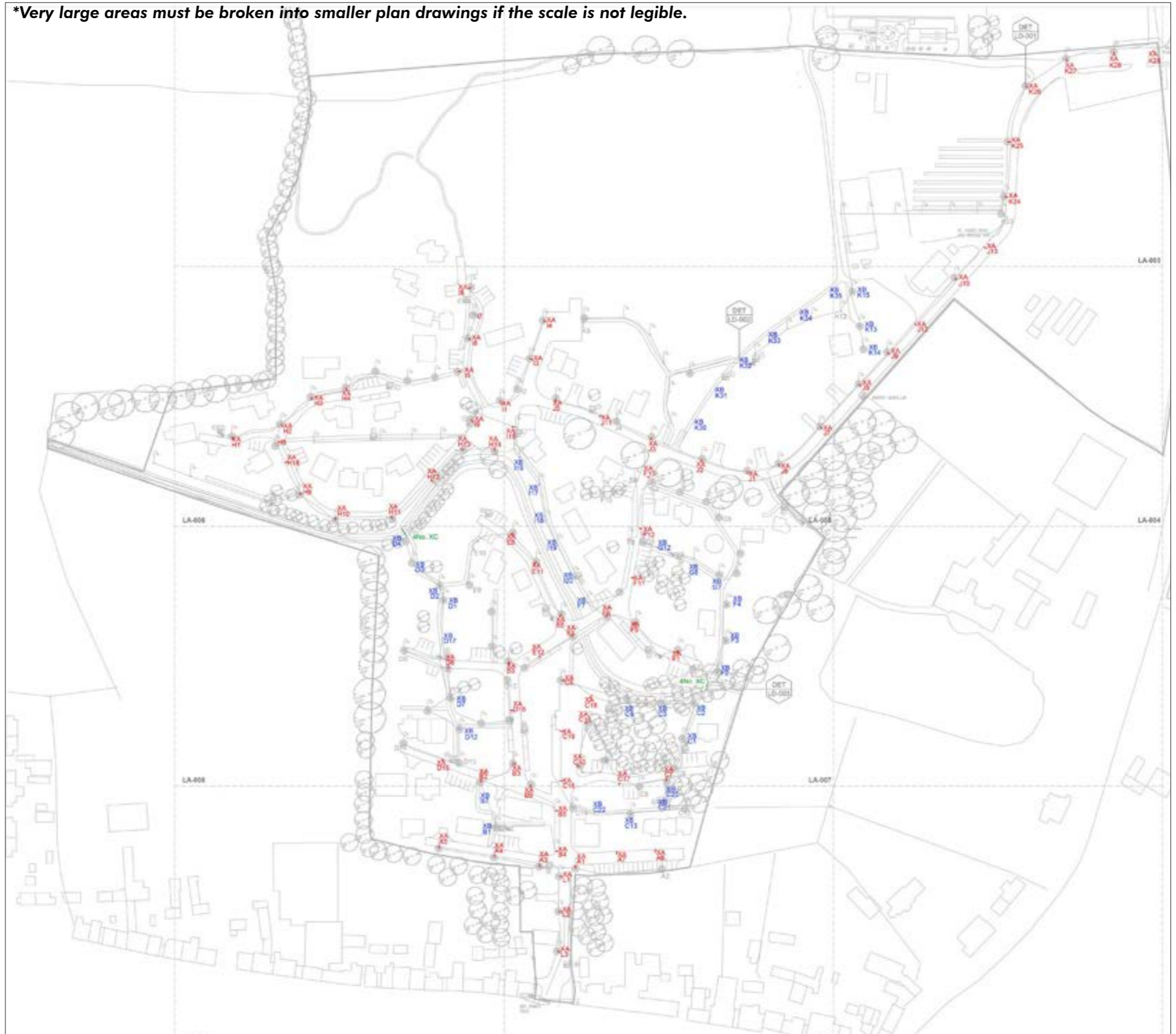

Lighting Equipment Specification

A specification needs to be submitted in order to provide the typical information shown on the right. This can be done in a report format or the manufacturers' cutsheet information can be compiled together for submission.

Additional suggestions: The following are not essential luminaire qualities from the point of dark skies. They are only suggested as best practice.

1) **Energy Efficiency** should not drop below 40 lumens per watt to avoid waste & to maximise the efficiency which LEDs can offer.



2) **Lamp life** should not drop below LM70 to ensure longevity. This means that the luminaire will still be able to produce 70% of its original output even after 50,000 hours of operation.

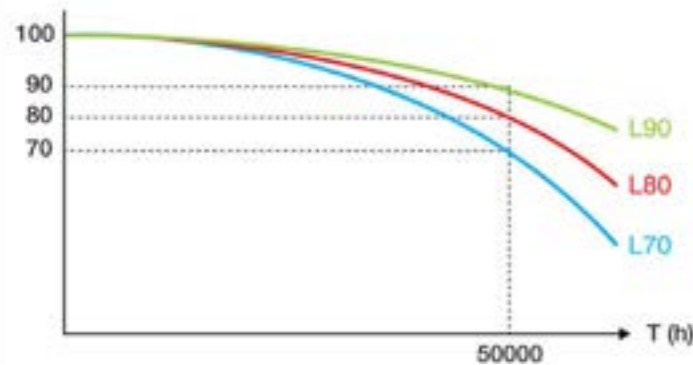

3) **Build Quality** To ensure durability of the specified equipment, it is advised to select luminaires with appropriate IP (Dust & water resistance) and IK (impact resistance) ratings.

Ingress Protection



Impact Protection - IK 08, 09, 10

Luminaire Reference	A	B	C
Manufacturer & Model	Urbis Schreder/ Axia 2.1 5241	Heper/ Drago Side	Stoane Lighting/ Exterior Channel SO
Image & Drawing			
Absolute Photometry (Beam distribution)			
Dimensions	650mm x 250mm x 132mm	180mm x 133mm x 1000mm	16.5mm x 16.5mm x 500mm
Colour Temp.	2200K	2200K	2200K
Wattage	26W	5W	9.3W/m
Output (Delivered)	3583 lumens	496 lumens	810 lumens per m
Efficiency	137lm/W	99.2lm/W	87lm/W per m
CRI	Ra 70	Ra 80	Ra 90
Dimmability	Dimmable	On/ Off	On/ Off
Means of Control	DALI	PIR (Passive InfraRed Sensor)	PIR (Passive InfraRed Sensor)
Adjustability	Adjustable	Fixed	Fixed
Accessories	Anti-glare louvres & 750mm bracket arm	n/a	n/a

*Any proposals such as the ones listed below require further inspection & justification:

- Wattage: ≥ 40W
- Lumen Output ≥ 4000 lumen
- Beam Distribution > 80°
- Colour Temperature: > 2700K
- No means of dimming or controllability

*For example, this luminaire's beam is above 80° (Not 0 ULOR) which means that it requires further inspection. See the integration detail on the next page to assess its suitability.

Lighting Details

The information must convey how the lighting will be integrated within the proposed scheme:

- Positioning within the wider context,
- Mounting height,
- Mounting angle & tilt angle,
- Mounting/ glare control accessories in situ,
- Dimensions in situ,
- Measures to mitigate glare.

***Any proposals such as the ones listed below require further inspection & justification:**

- **Adjustability: Angled > 0°**
- **Height: Mounted at ≥ 8m height.**

Tilt adjustments are only meant for accommodating luminaires which need to be mounted on angled surfaces or to overcome specific design challenges. In such conditions, the luminaire may be tilted by up to 20°. Otherwise, all luminaires must be angled perpendicular to the ground.

Luminaire Reference

Plan drawing showing the spacing (This can be included in the large plan layout drawing or in partial plans focusing on specific areas of interest.)

Section or elevation drawings showing the luminaire integration & its mounting height within the context. (Multiple sections & scaled drawings can be submitted as long as the detail integration is expressed in a legible way.)

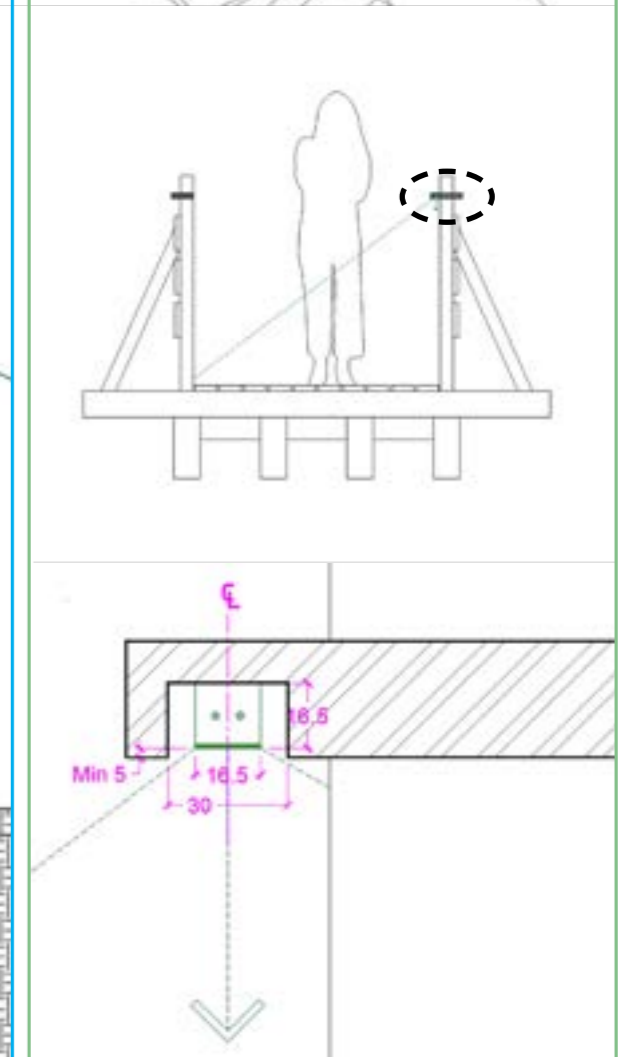
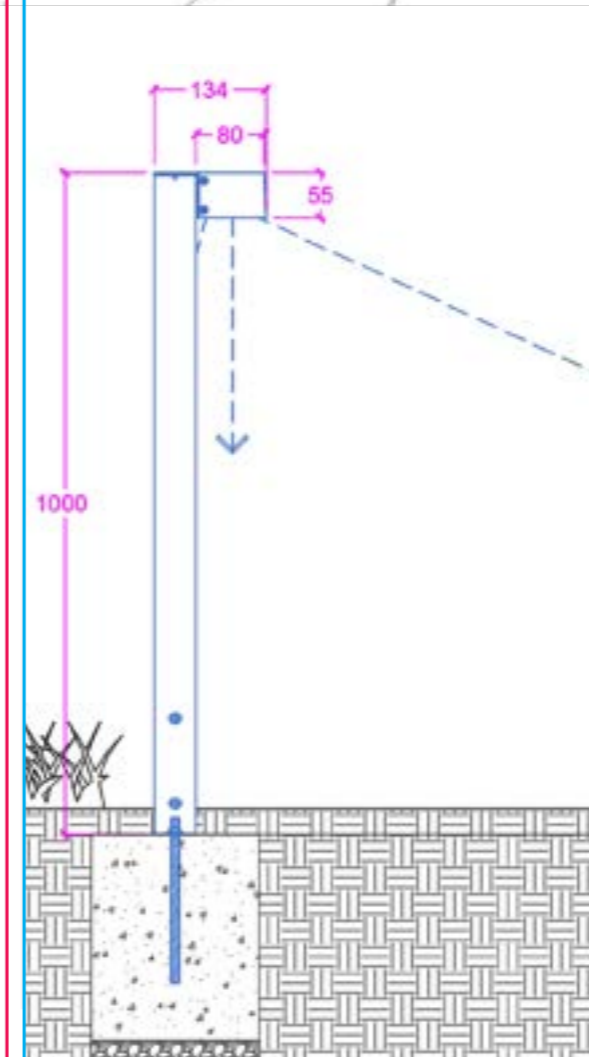
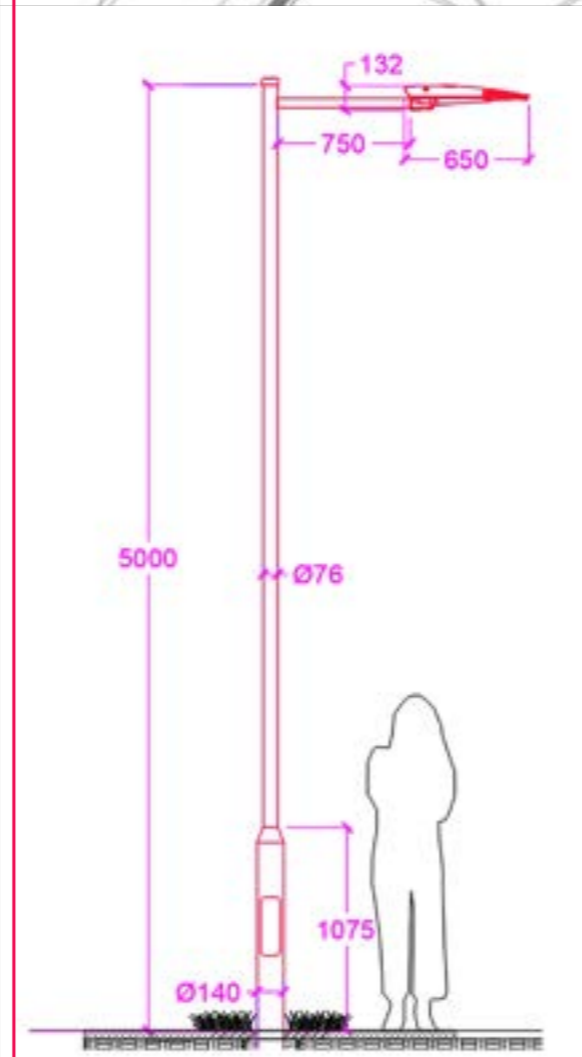
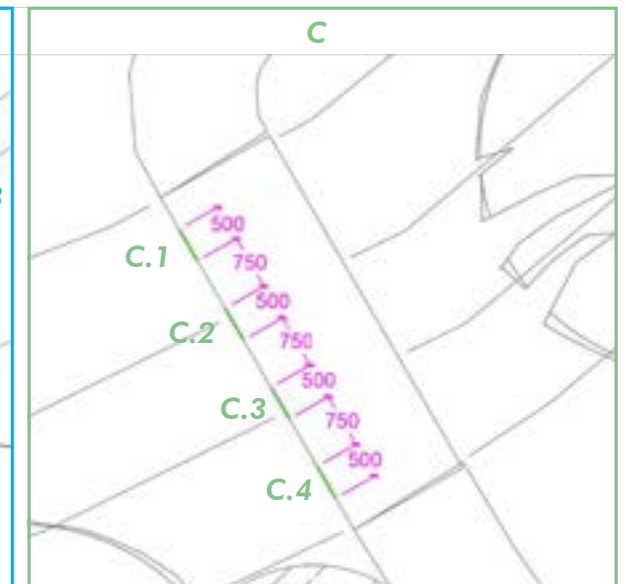
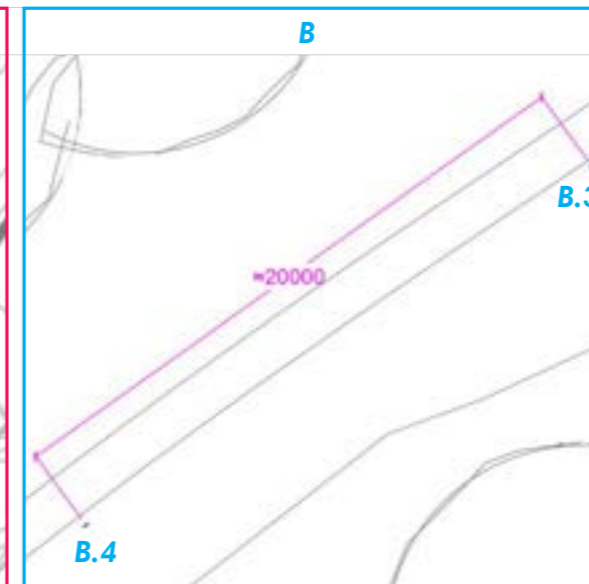
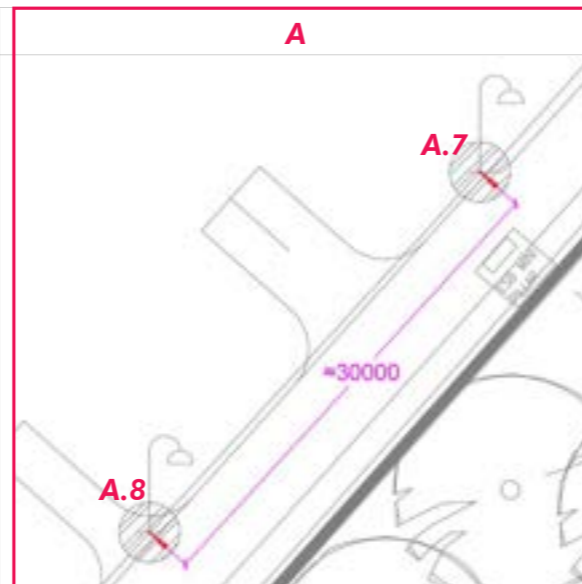

Column Detail: The information above illustrates that the columns are mounted at 5m height with 30m spacing, their bracket arms are extended outwards by 750mm and the luminaires are angled perpendicular to the ground.

Bollard Detail: The bollard is 1m tall, mounted at 20m spacing and it's source is perpendicular to the ground.

Handrail Detail: This luminaire produces 108° beam (above the 80° cut-off threshold) but the luminaire is well-recessed within the timber handrail & fixed facing the ground which proves that the detail doesn't pose any threat to dark skies. ***Any luminaire proposal which does not comply with 0 ULOR rating must be justified with a similar exercise as above.**

Calculations

The lighting calculation is a very important part of the assessment. Any software such as Relux, Dialux, Lighting Reality, Agi 32 and etc. can be used as long as the information is presented in a clear and legible manner.

The calculation can consist of pseudo (false) colours, luminance, illuminance imaging, isolux diagrams, numerical value tables. See the examples shown on the right.

Calculations showing typical details lighting illuminance contours (lux) clearly indicating extent of lighting on horizontal and vertical planes to show the impact within the site, on buildings and surrounding landscape.

Details showing lighting calculations indicating illuminance and/or luminance, uniformity, maintained averages, lowest and highest values. All calculations must be based on a unity maintenance factor (1.0) with lighting at 100% intensity. Calculation planes should be placed at the relevant surface level or no more than 1m away from it.

Lighting standards are for guidance purposes - each lighting task and risk assessment should be tailored to every individual site.

If you don't know what lux levels to aim for, you can refer to the British Standards for guidance as per your specific development type. Clarify if the project is expected to meet certain lighting standards or regulations. If not, all projects are encouraged to use light judiciously.

***Any outdoor or public realm lighting scheme achieving above 15 lux average for predominantly pedestrian traffic requires further inspection & justification.**

***Any sports lighting project achieving above 500 lux average requires further inspection & justification.**

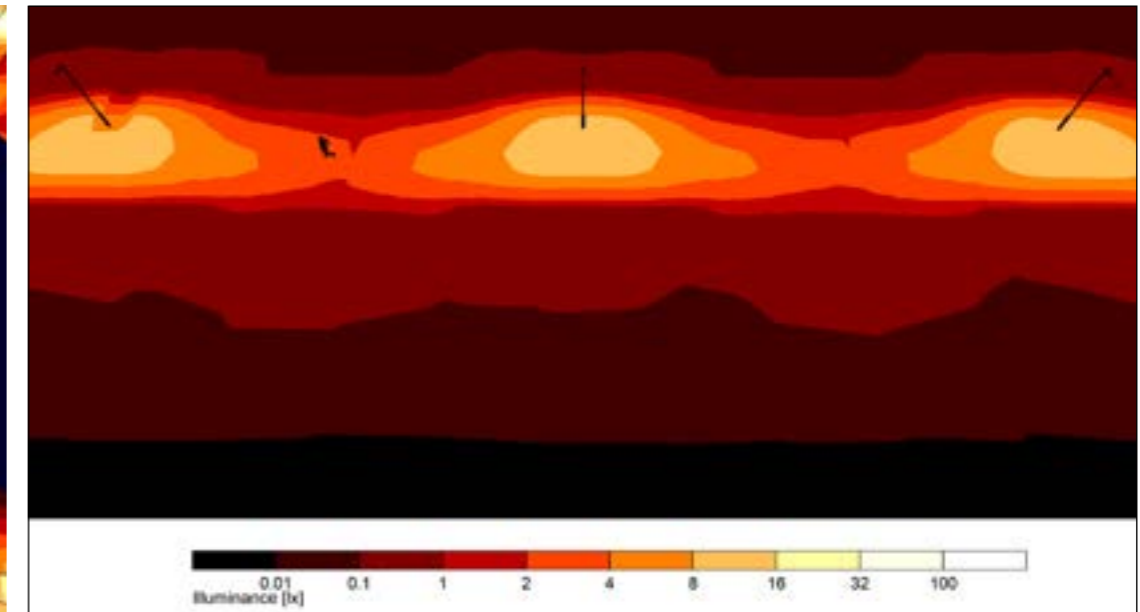
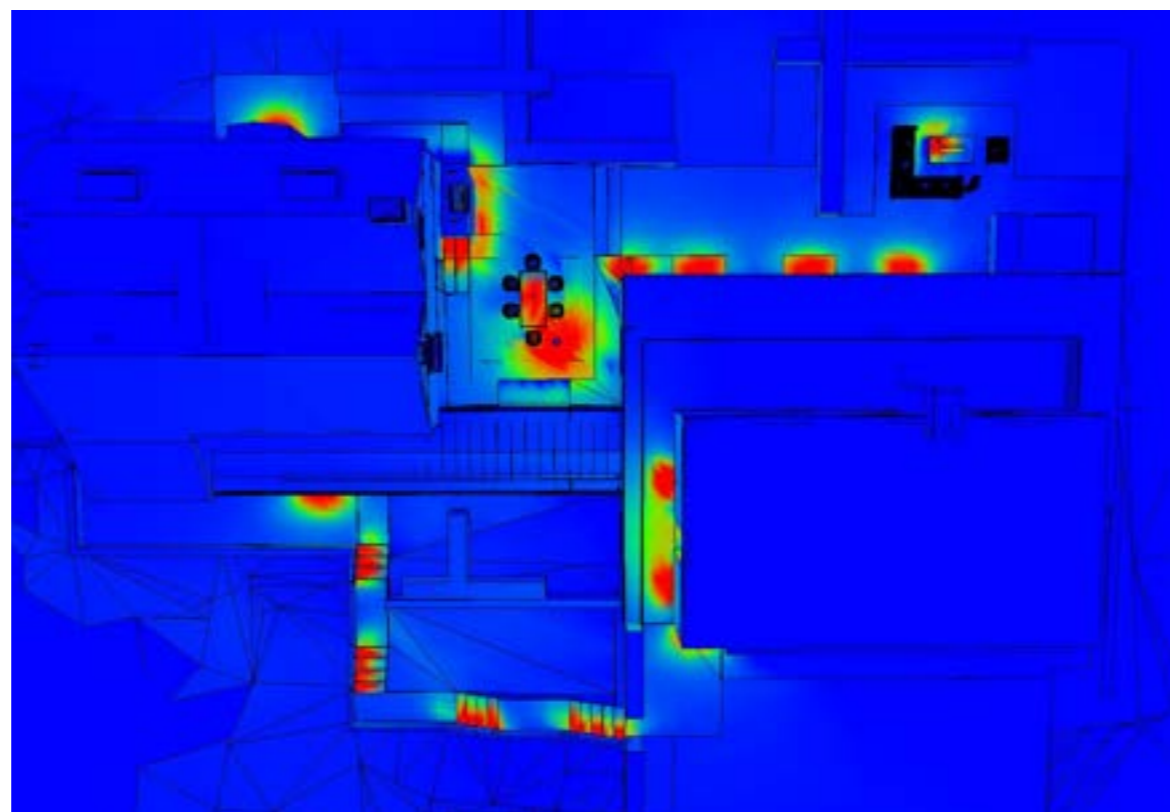
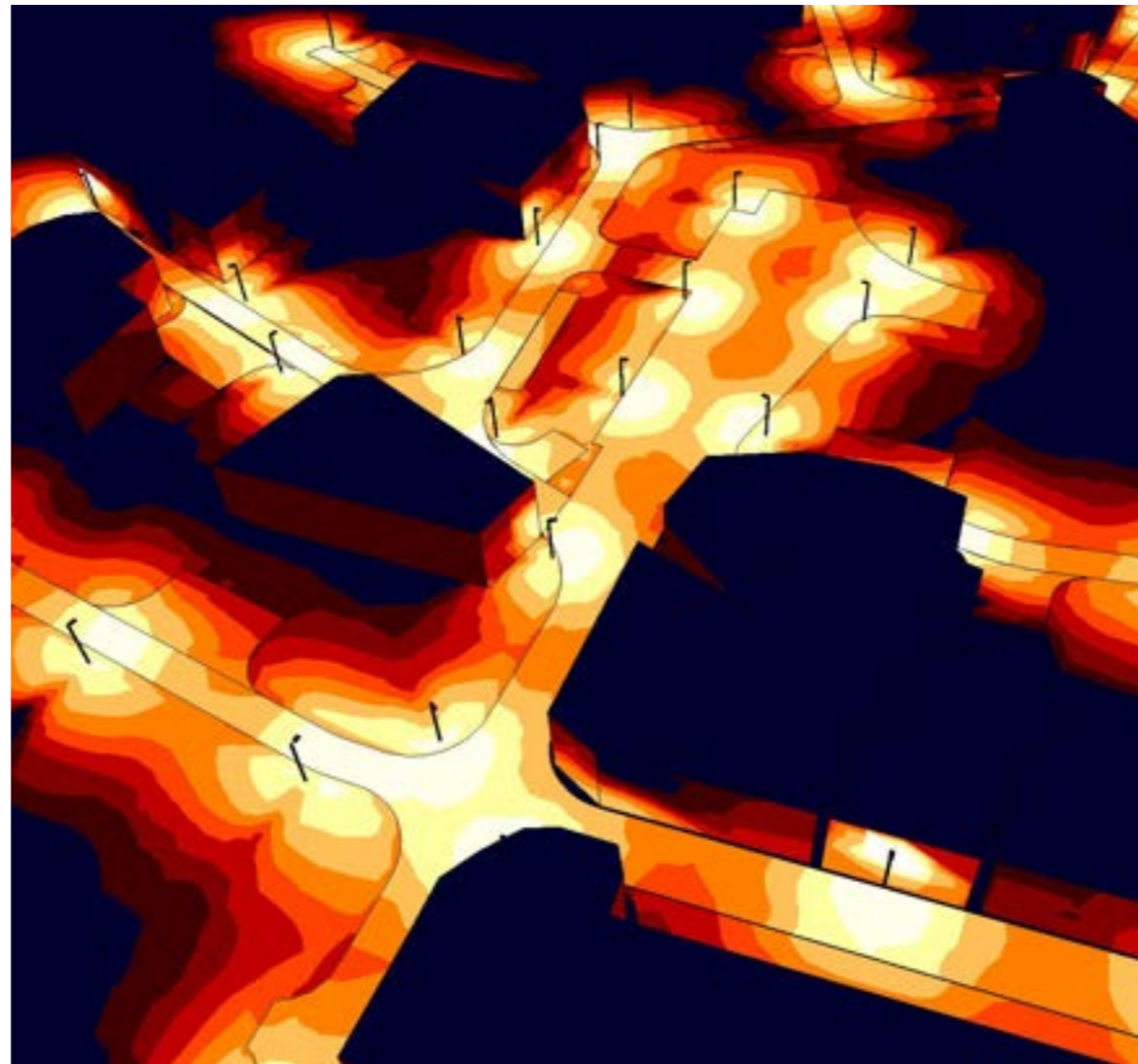

329	243	284	242	196	249	286	246	310	7.99 m
355	259	319	242	241	244	320	258	354	
292	350	370	234	261	234	377	347	280	
290	390	421	253	268	256	428	381	272	
332	375	378	259	261	264	379	366	329	
359	277	323	244	239	250	313	280	321	
303	256	296	250	208	260	297	267	296	
									-7.99
									-16.38
									16.38 m
E_{av} [lx]	E_{min} [lx]	E_{max} [lx]	u_0	E_{min} / E_{max}					
299	196	428	0.66	0.46					

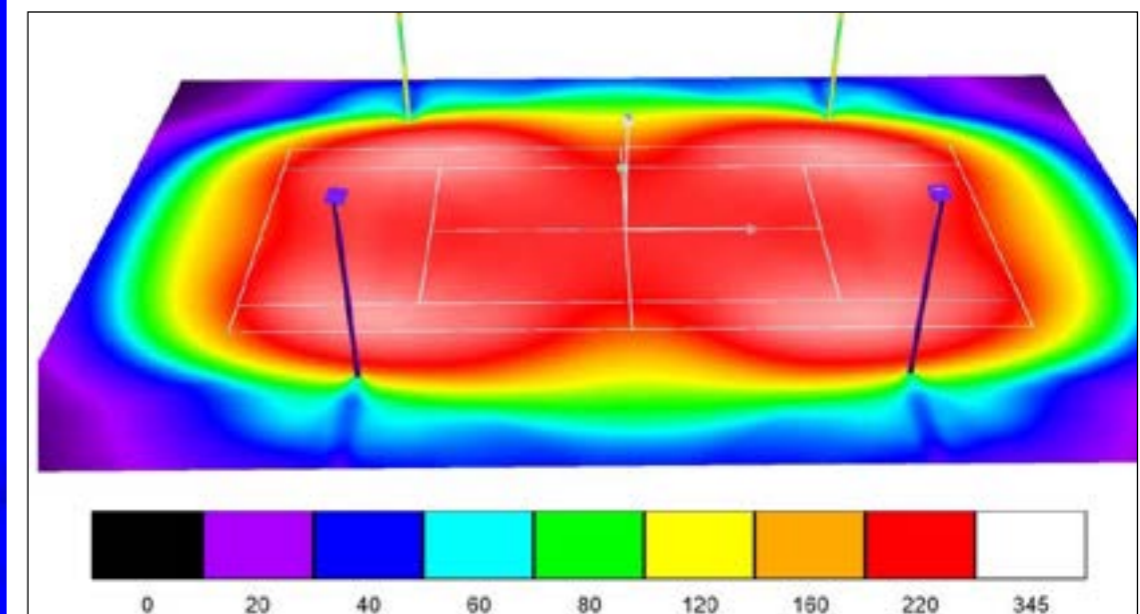

Calculations

If the project is too large to convey everything on a single calculation plane, it is suggested to split the area into multiple calculation surfaces to convey information in a clear manner. The calculation can be one big composite or it can be broken down to individual areas. Average and minimum lux values for all areas need to be conveyed along with the uniformity value.

Uniformity

Uniformity is the ratio of the minimum lighting level to the average lighting level in a specified area. Uniformity suggests that the minimum lux level is above zero which results with a more homogeneous illumination. If a project is not expected to meet a standard, it is perfectly acceptable for the lighting effect to be intermittent. Achieving uniformity can prove helpful if the project is expected to meet a certain lighting standard at a lower average lux level. See the example below.

Omni-directional Vs Directional

The bollard lighting comparison below shows the difference between the glowing illumination with poor uniformity against directional illumination with good uniformity. Two different styles of 7W bollards made by the same manufacturer were used in order to achieve 10 lux for this example. When light is directional and homogeneous, it can afford to be less intense thanks to its high efficiency. Glowing or diffused lights on the other hand can cause glare, wasted light and uncontrolled spill resulting in low efficiency.

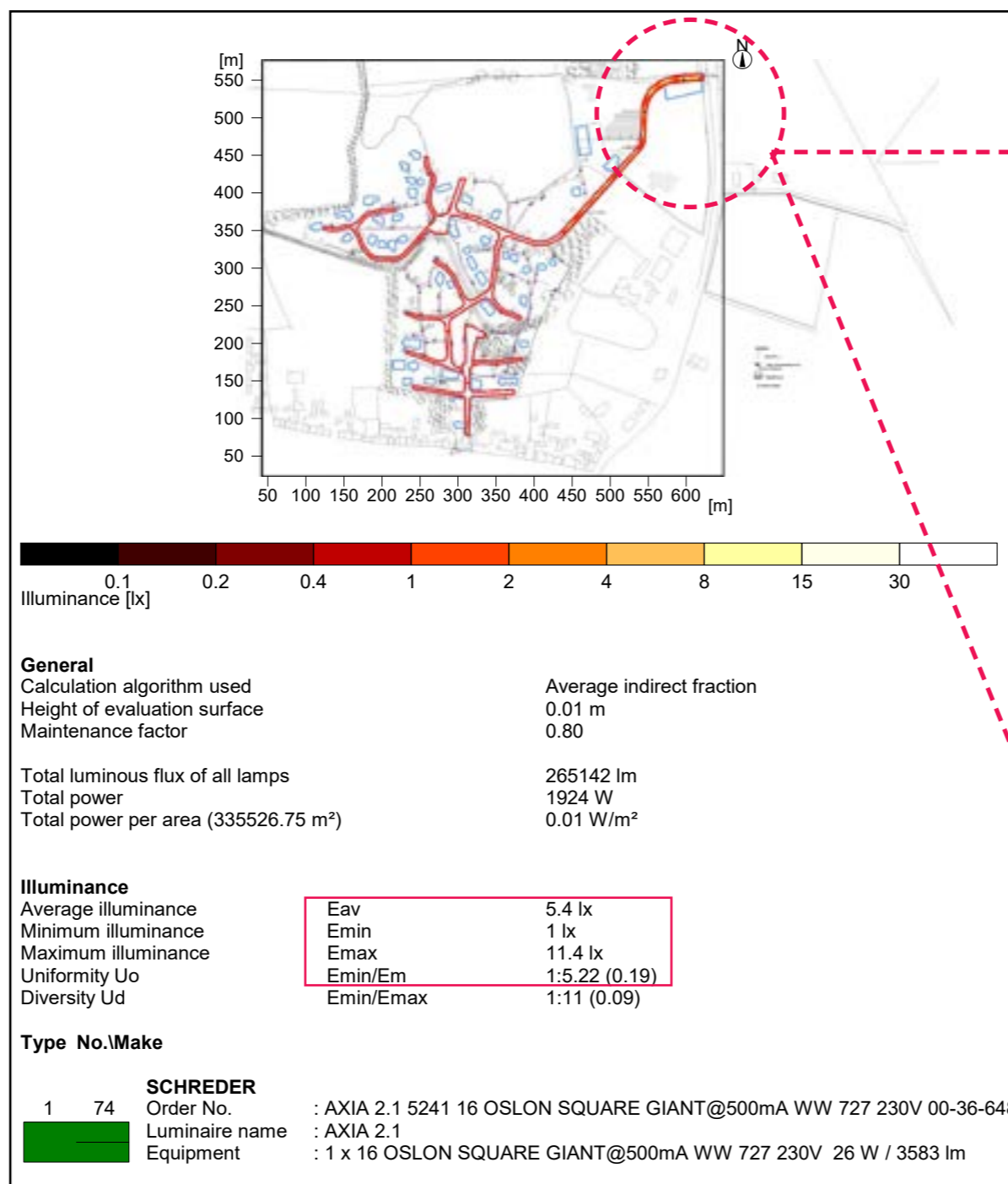

Large areas must be broken into smaller & legible calculation planes.

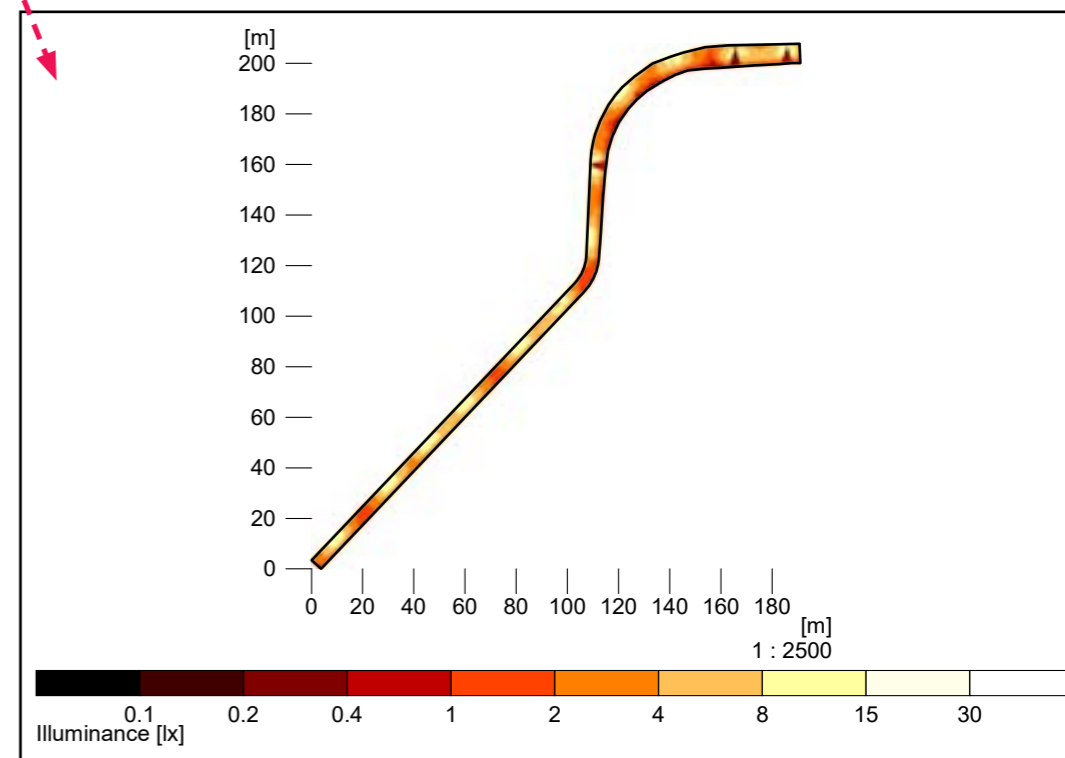
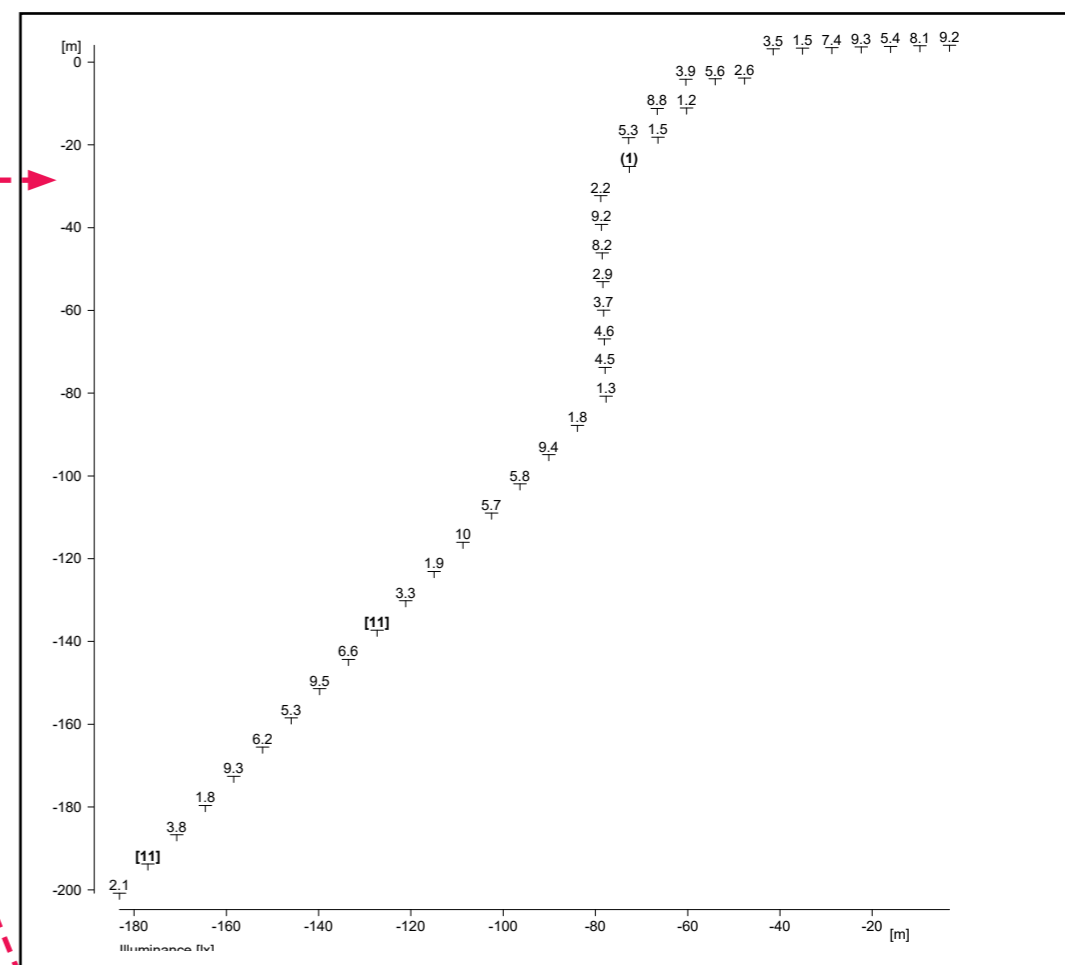

Example showing numerical value table and pseudo colour plane options showing the illuminance level.



Omi-directional illumination:
10lux with 0.05 uniformity/ 25% dimming
Low efficiency & High glare

Directional illumination:
10lux with 0.2 uniformity/ 75% dimming
High efficiency & Low glare

There will be occasions where the existing lighting may need to be improved with quick solutions without replacing the entire luminaire. In that case, the following tips can be taken into consideration.

One of the most common luminaire types used by the industrial estates, farms and domestic gardens tend to be the flat phosphor LED floodlights such as the one shown below. Here are some quick tips:

1) Don't use light:

- If you don't need it.
- too powerful for its purpose ($\geq 40W$)
- in cool colour temperature ($\geq 2700K$)
- tilted outwards.

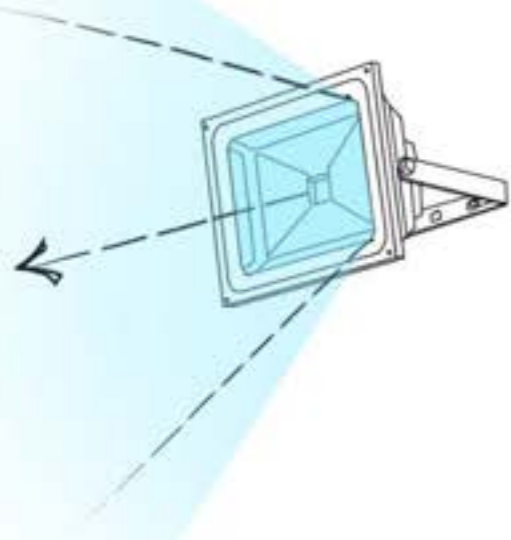

2) Keep:

- it angled down.
- shield to reduce glare & beam distribution.

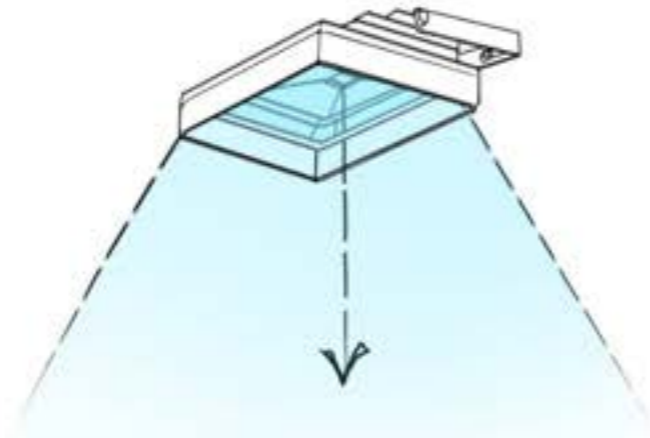

3) Use:

- gels & filters to warm the colour temperature ($\leq 2700K$)
- additional layers to reduce the intensity if the light is too bright (and if dimming is not an option.)

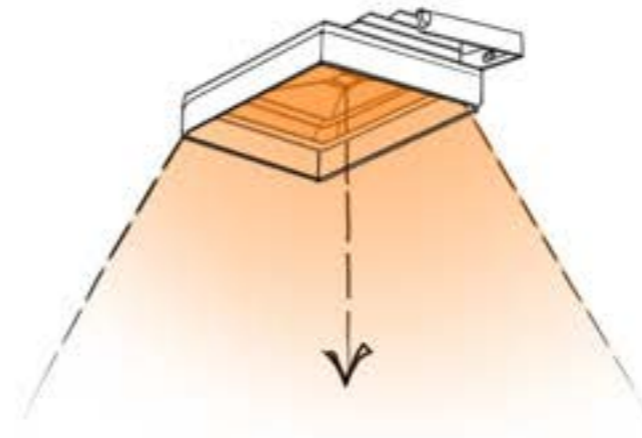

4) Apply:

- dimming or switch off at late hours.
- PIR sensors to avoid energy waste.

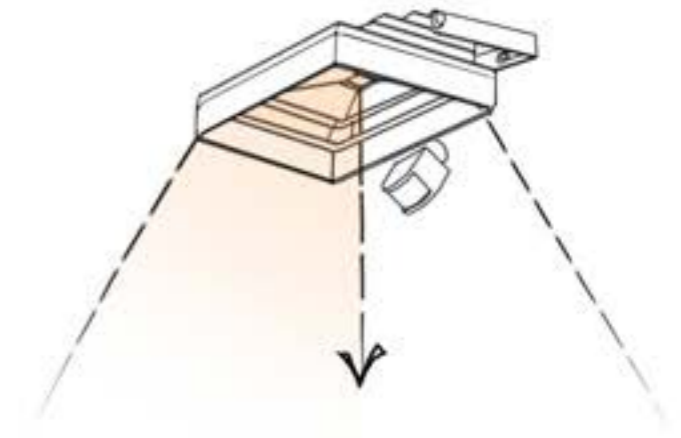

Luminaire with adjustable bracketry.



Custom-baffle or shield.

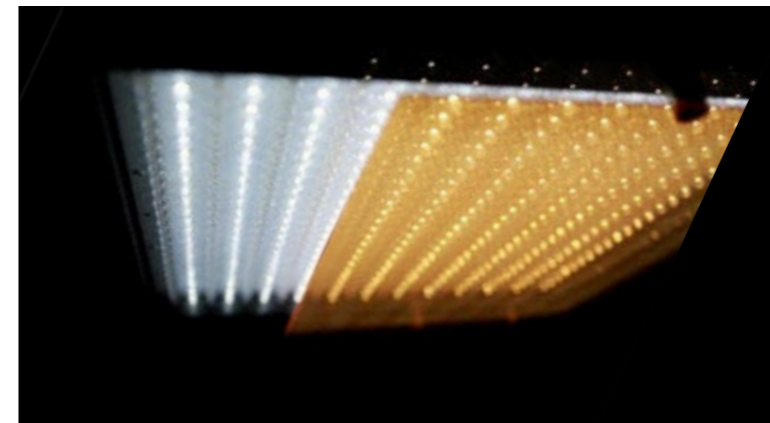

Gels & filters to warm up the colour temperature. Example at the [link](#).



PIR sensors can be used for a group or individual lights. See examples [here](#) or [here](#).

Luminaire Selection

There is a wide range of luminaires available for the domestic, commercial and professional market. There are a couple of key features to bear in mind when choosing luminaires: Warm colour temperature, suitable power and intensity, acceptable beam distribution, mounting height and tilt angle employed with a dimming or switch-off strategy.

Domestic

Any luminaire that is: $\leq 2700K$, $\leq 10W$, ≤ 1000 lumens with $\leq 80^\circ$ beam mounted at $\leq 3m$, angled downwards, ideally with baffle & PIR sensor is acceptable.

Industrial

Any luminaire that is: $\leq 2700K$, $\leq 40W$, ≤ 4000 lumens with $\leq 80^\circ$ beam mounted at $\leq 8m$, angled downwards with baffle & PIR sensor would be acceptable.

Luminaire VS Source

Luminaire is a term which refers to the entire light fitting: the housing and the light source. Most domestic luminaires house interchangeable bulbs which are easy to replace. In most cases, modern LED luminaires that are meant for architectural, commercial & industrial purposes have integral sources which cannot be removed or replaced. If changing the source is an option, environmentally friendly options are widely available.



Bulb Example
4W 420lumens domestic bulb with reflector cap.



Examples of Acceptable / Unacceptable Lighting Fixtures

Unacceptable / Discouraged

Fixtures that produce glare and light trespass



Unshielded Floodlights or Poorly-shielded Floodlights

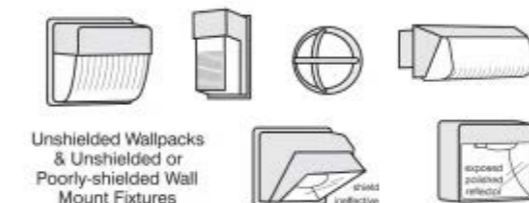

Unshielded Wallpacks & Unshielded or Poorly-shielded Wall Mount Fixtures

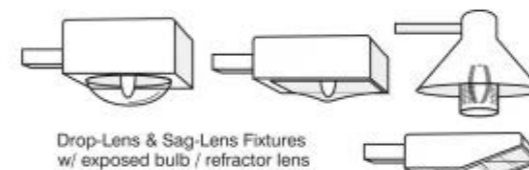

Drop-Lens & Sag-Lens Fixtures w/ exposed bulb / refractor lens

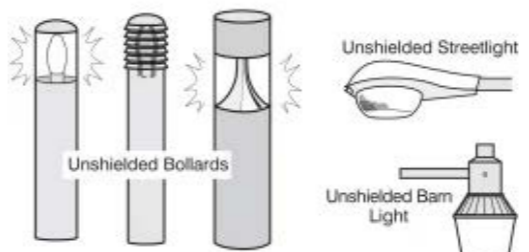

Unshielded Streetlight

Unshielded Barn Light



Louvered 'Marine' style Fixtures

Unshielded 'Period' Style Fixtures

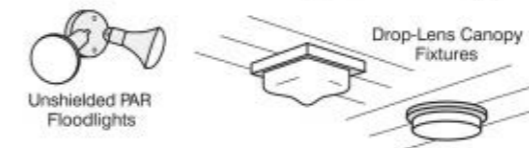

Unshielded PAR Floodlights

Drop-Lens Canopy Fixtures

Acceptable

Fixtures that shield the light source to minimize glare and light trespass and to facilitate better vision at night

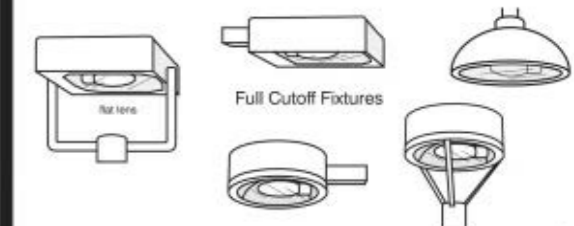

Full Cutoff Fixtures



Fully Shielded Wallpack & Wall Mount Fixtures

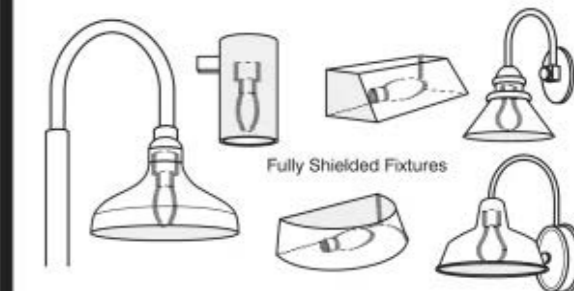

Fully Shielded Fixtures

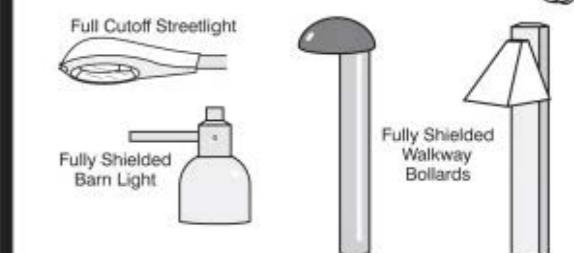

Full Cutoff Streetlight

Fully Shielded Walkway Bollards



Fully Shielded Decorative Fixtures

Fully Shielded 'Period' Style Fixtures

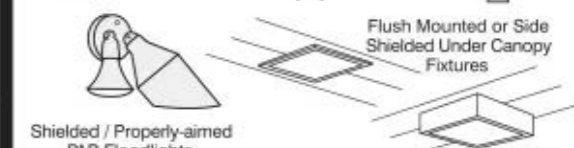

Shielded / Properly-aimed PAR Floodlights

Illustrations by Bob Crelin© 2005. Rendered for the Town of Southampton, NY. Used with permission.



**Warm colour temperature, suitable power and intensity, acceptable beam distribution, mounting height and tilt angle employed with a dimming or switch-off strategy.*

Extract from Dark Sky Assessment Guide by the DarkSky International
Illustration by Bob Crelin.

Energy Saving & Carbon Emissions

Here are some concrete examples, how responsible use of light can improve the night-time experience whilst protecting the environment. These savings figures are direct outcomes of successful dark sky initiatives.

In order to boost the energy-efficiency of the scheme, it is advised to take every single luminaire's efficiency and longevity into consideration to maximise the sustainability potential of any project.



80% ANNUAL ENERGY REDUCTION

Plas Y Brenin Outdoor Centre in Snowdonia, Wales refurbished its outdoor lighting with an environmental ethos which resulted with the elimination of the sky glow shown above. Since the completion of the project in late 2021, there has been nearly 200 bats, some owls and a Pine Marten have been observed to move back in the area.



8,500 kWh

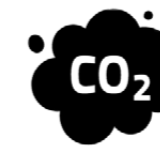

2 Tonnes of CO2e



£2,550 (30p/kWh)



1.2 Billion lumens



70% ANNUAL ENERGY REDUCTION

Newport Dark Sky Masterplan in County Mayo, Ireland is an ongoing town-wide lighting improvement project with ambitious reduction targets. As part of the overall project, glare and overpowering floodlighting of the landmark architecture such as the St. Patrick's Church had gone through a reconsideration. Reduction of glare & brightness have enhanced the visual comfort whilst allowing the building silhouette to be appreciated through improved contrast.



4,200kWh



1 Tonne of CO2e



£1,260 (30p/kWh)



0.6 Billion lumens

<p>1) Lighting Justification & Purpose (See page 13)</p> <p><input type="checkbox"/> Does the Design & Access Statement to explain the purpose & necessity of illumination?</p> <p><input type="checkbox"/> Is the proposed development type explained?</p>
<p>2) Baseline (See page 13)</p> <p><input type="checkbox"/> What lighting is currently on the site? How is it used and what for?</p> <p><input type="checkbox"/> Is there potential to improve existing lights to achieve a net reduction?</p> <p><input type="checkbox"/> Is there a night-time survey of the surrounding context? What data is it based on?</p>
<p>3) Impact Assessment & Good Lighting Outcomes (See page 13)</p> <p><input type="checkbox"/> Where is the project located?</p> <p><input type="checkbox"/> Are the impacts on the wider landscape, ecology, night sky and sensitive habitats or view-points identified?</p> <p><input type="checkbox"/> Explain how the lighting makes a positive contribution to the good lighting outcomes?</p>
<p><input type="checkbox"/> 4) Lighting Layouts (See pages 15 & 46)</p> <p>Is the lighting layout plan submitted clearly showing where all the proposed, retained and replaced luminaires and their positions?</p>
<p><input type="checkbox"/> 5) Lighting Equipment Schedule (See page 15 & 47)</p> <p>Is there a lighting equipment specification which is clearly stating every type of proposed luminaires, their total load, lumen output, beam distribution and colour temperature? (This can be presented in the designer's own template or as per the manufacturer's information cut-sheet)</p>
<p><input type="checkbox"/> 6) Lighting Details (See pages 15 & 48)</p> <p>Are there drawings which show the mounting method, types, height, tilt angles & direction for the different luminaires and associated equipment on the building(s) or within the site?</p>
<p>7) Lighting Calculations (See pages 16, 49, 50)</p> <p><input type="checkbox"/> Is the lighting calculation submitted? Does it clearly show the average lux level (including minimum and maximum levels) and uniformity of both horizontal & vertical planes?</p> <p><input type="checkbox"/> Are any relevant lighting standards applied to any exterior part of the site or the project?</p>
<p>8) Design Details & Mitigation Considerations (See page 16)</p> <p><input type="checkbox"/> Is there a section which conveys what design or mitigation measures were taken and what opportunities were found in order to reduce the overall light pollution level?</p>
<p><input type="checkbox"/> 9) Control System & Operation (See page 16)</p> <p>What are the dimming profiles, control strategies and curfews implemented?</p>
<p><input type="checkbox"/> 10) Visuals (See page 45)</p> <p>Are there any illustrative visuals, computer generated imagery or diagrams available?</p>

- Where any of the below apply (excess illumination, glare or upward light projection is highly likely), does the lighting design fully justify the exceptional need & include suitable mitigation measures?**
- Are there any proposed luminaire(s) above the following threshold?
 $\leq 2700K, \leq 40W, \leq 4000$ lumens with $\leq 80^\circ$ beam mounted at $\leq 8m$, angled down.
- Are there any luminaire(s) without a dimming profile, switch off or curfew strategy?
- Are there any luminaire(s) not angled perpendicular to the floor plane?
- Are there any luminaire(s) angled above 20° tilt angle?
- Is the project expected to meet any particular lighting standards?
- Is the project expected to deliver over 15 lux average for pedestrian-oriented projects?
- Is the project expected to deliver over 10 lux average per 100m² area?
- Is the outdoor sports field(s) expected to achieve light levels above the standards set in the **Guidance from Sport England** ?

Designing out light pollution in Cumbria, the Yorkshire Dales National Park and the Arnside and Silverdale National Landscape

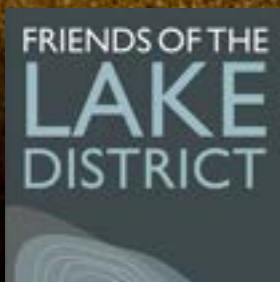

dark source